

**EN**

**INSTRUCTIONS**  
LOCAL AIR CONDITIONER

**Table of contents**

**Information on the use of these instructions** ..... 2

**Safety** ..... 2

**Information about the device**..... 5

**Transport and storage**..... 6

**Assembly and start-up**..... 7

**Operation** ..... 10

**Errors and faults**..... 12

**Maintenance** ..... 13

**Technical annex**..... 17

**Disposal** ..... 21

**Information on the use of these instructions**

**Symbols**



**Danger**

This symbol indicates dangers to the life and health of persons due to extremely flammable gas.



**Warning**

This signal word indicates a hazard with an average risk level which, if not avoided, can result in serious injury or death.



**Warning of electrical voltage**

This symbol indicates dangers to the life and health of persons due to electrical voltage.

**Notice**

This signal word indicates important information (e.g. material damage), but does not indicate hazards.



**Info**

Information marked with this symbol helps you to carry out your tasks quickly and safely.



**Follow the manual**

Information marked with this symbol indicates that the instructions must be observed.

You can download the current version of these instructions via the following link:

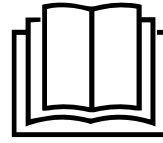

PAC 2015 E



<https://hub.trotec.com/?id=47581>

**Safety**

**Read this manual carefully before starting or using the device. Always store the manual in the immediate vicinity of the device or its site of use.**



**Warning**

**Read all safety warnings and all instructions.**

Failure to follow the warnings and instructions may result in electric shock, fire and/or serious injury.

**Save all warnings and instructions for future reference.**

This appliance can be used by children aged from 8 years and above and persons with reduced physical, sensory or mental capabilities or lack of experience and knowledge if they have been given supervision or instruction concerning use of the appliance in a safe way and understand the hazards involved.

Children shall not play with the appliance. Cleaning and user maintenance shall not be done by children without supervision.

- Do not use the device in potentially explosive rooms or areas and do not install it there.
- Do not use the device in an aggressive atmosphere.
- Place the device in an upright and stable position on a horizontal and stable surface.
- Let the device dry out after a wet clean. Do not operate it when wet.
- Do not use the device with wet or damp hands.
- Do not expose the device to directly squirting water.
- Never insert any objects or limbs into the device.
- Do not cover the device during operation.
- Do not sit on the device.
- This appliance is not a toy. Keep away from children and animals.
- Check accessories and connection parts for possible damage prior to every use of the device. Do not use any defective devices or device parts.

- Ensure that all electric cables outside of the device are protected from damage (e.g. caused by animals). Never use the device if electric cables or the power connection are damaged!
- The mains connection must correspond to the specifications in the Technical annex.
- Insert the mains plug into a properly fused mains socket.
- Observe the technical data when selecting extensions to the power cable. Completely unroll the extension cable. Avoid electrical overload.
- Before carrying out maintenance, care or repair work on the device, remove the mains plug from the mains socket. Hold onto the mains plug while doing so.
- Switch the device off and disconnect the power cable from the mains socket when the device is not in use.
- Do not under any circumstances use the device if you detect damages on the mains plug or power cable. If the supply cord is damaged, it must be replaced by a special cord or assembly available from the manufacturer or its service agent.  
Defective power cables pose a serious health risk!
- When positioning the device, observe the minimum distances from walls and other objects as well as the storage and operating conditions specified in the Technical annex.
- Make sure that the air inlet and outlet are not obstructed.
- Do not remove any safety signs, stickers or labels from the device. Keep all safety signs, stickers and labels in legible condition.
- Make sure that the suction side is kept free of dirt and loose objects.
- Only transport the device in an upright position with an emptied condensation tray or drain hose.
- Discharge the collected condensate before transport and storage. Do not drink it. Health hazard!
- Use batteries of type AAA.
- Do not insert rechargeable batteries into the remote control.
- Never charge batteries that cannot be recharged.
- Different types of batteries and new and used batteries must not be used together.
- Insert the batteries into the battery compartment according to the correct polarity.
- Remove discharged batteries. Batteries contain materials hazardous to the environment. Dispose of the batteries according to the national regulations.
- Remove the batteries from the remote control if you will not be using the device for a longer period of time.
- Never short-circuit the terminals of batteries!
- Do not swallow batteries! If a battery is swallowed, it can cause severe internal burns within 2 hours! These burns can lead to death!
- If you think batteries might have been swallowed or otherwise entered the body, seek medical attention immediately!
- Keep new and used batteries and an open battery compartment away from children.
- If the battery compartment does not close securely, stop using the product via the remote control.



### **Safety warnings for devices containing flammable refrigerants**



#### **Warning**

Do not drill into or burn.



#### **Warning**

Do not use any means other than those recommended by the manufacturer for accelerating the defrosting process or cleaning the device.



#### **Warning**

Every person working with or at the refrigerant circuit must be able to provide a certificate of qualification issued by a body accredited by the industry, demonstrating their competence in the safe use of refrigerants based on a procedure well-known in the industry.

- Store the appliance in a room without continuously operating open flames (for example an operating gas appliance) or other potential ignition sources (for example an operating electric heater, hot surfaces);
- Please note that the refrigerant is odourless.
- Only install the device in compliance with the national installation regulations.
- Please observe the local regulations.
- Observe the national regulations for gas installations.
- Only install, operate and store the device in a room measuring more than 7 m<sup>2</sup>.
- Store the device in a way that no mechanical damage can occur.
- R290 is a refrigerant that complies with European environmental regulations. No part of the cooling circuit may be perforated.
- Observe the maximum refrigerant capacity in the technical data.
- Service work may only be carried out in accordance with the manufacturer's specifications. If maintenance and repair work require the support of additional persons, the person trained in handling flammable refrigerants shall continuously supervise the work carried out.

- The entire refrigerant circuit is a maintenance-free, hermetically sealed system and may only be maintained or repaired by specialist companies for cooling and air-conditioning or by the manufacturer.

**Intended use**

Only use the device for cooling, ventilating and dehumidifying indoor air whilst adhering to the technical data.

Any use other than the intended use is regarded as misuse.

**Reasonably foreseeable misuse**

- Do not place the device on wet or flooded ground.
- Do not place any objects, e.g. clothing, on the device.
- Do not use outdoors.
- Never immerse the device in water.
- Do not make any unauthorised modifications, alterations or structural changes to the device.
- Do not use the device in the immediate vicinity of swimming pools, bathtubs and showers.

**Personnel qualification**

People who use this device must:

- have read and understood the instructions, especially the Safety chapter.

Maintenance tasks which require the housing to be opened must only be carried out by specialist companies for cooling and air-conditioning or by the manufacturer.

**Safety signs and labels on the device**

**Notice**

Do not remove any safety signs, stickers or labels from the device. Keep all safety signs, stickers and labels in legible condition.

The following safety signs and labels are attached to the device:

**WARNING • WARNUNG • ATTENTION**

**DE** Das Gerät muss in einem Raum mit einer Grundfläche größer als 7 m<sup>2</sup> aufgestellt, betrieben und gelagert werden.

**EN** Appliance shall be installed, operated and stored in a room with floor area larger than 7 m<sup>2</sup>.

**FR** L'appareil doit être installé, utilisé et entreposé dans une pièce avec une surface supérieure à 7 m<sup>2</sup>.



**A3**



**Follow the manual**

This symbol indicates that the instructions must be observed.



**Follow the repair manual**

Disposal, maintenance and repair work of the refrigerant circuit may only be carried out in accordance with the manufacturer's specifications and by persons having a certificate of qualification. A corresponding repair manual is available from the manufacturer upon request.

**!!! ACHTUNG !!!**

1. Vor Inbetriebnahme MIND. 12 STUNDEN aufrecht und still stehen lassen! Das schützt den Kompressor, verlängert die Lebensdauer erheblich und verhindert so einen Verlust der Kühlleistung.
2. Das Klimagerät muss immer BESONDERS VORSICHTIG auf den Boden gestellt werden! Ansonsten können Mikrorisse in der Bodenplatte und der Kondensatwanne entstehen, was dazu führt, dass Kondenswasser auf den Boden tropft.

Für Schäden, die durch unsachgemäßen Gebrauch entstehen, übernehmen wir KEINE GEWÄHRLEISTUNG!

---

**!!! WARNING !!!**

1. Before operation, stand upright and rest for MIN 12 HOURS! This protects the compressor, greatly extending its life and preventing loss of cooling performance.
2. The air conditioner must always be placed on the floor with CAUTION! Otherwise, microcracks may form in the bottom plate and the condensate pan, causing condensation to drip onto the floor.

For damages caused by improper use, WARRANTY WILL BE NULL AND VOID!

---

**!!! ATTENTION !!!**

1. Avant la mise en service, laisser immobile en position verticale PENDANT AU MOINS 12 HEURES ! Cela protège le compresseur, prolonge sensiblement la durée de vie et évite ainsi une diminution des performances de refroidissement.
2. Le climatiseur doit toujours être posé sur le sol AVEC LES PLUS GRANDES PRÉCAUTIONS ! Sinon, des micro-fissures risquent de se former dans le socle ou le bac de récupération de l'eau de condensation, ce qui entraînerait que cette dernière coule sur le sol.

Toute utilisation incorrecte ou non conforme entraîne L'EXTINCTION DE LA GARANTIE !

## Residual risks



### **Danger**

#### **Natural refrigerant propane (R290)!**

H220 – Extremely flammable gas.

H280 – Contains gas under pressure; may explode if heated.

P377 – Leaking gas fire: Do not extinguish, unless leak can be stopped safely.

P410+P403 – Protect from sunlight. Store in a well-ventilated place.



#### **Warning of electrical voltage**

Risk of electric shock!

Risk of an electric shock if the device comes into contact with water!

Do not use this device in the immediate vicinity of bathtubs, showers or swimming pools!



#### **Warning of electrical voltage**

Work on the electrical components must only be carried out by an authorised specialist company!



#### **Warning of electrical voltage**

Before any work on the device, remove the mains plug from the mains socket!

Do not touch the mains plug with wet or damp hands.

Hold onto the mains plug while pulling the power cable out of the mains socket.



#### **Warning of electrical voltage**

Risk of electric shock!

The device is not protected against water.

There is a risk of electric shock!

Never use the device in areas where dripping, spraying or running water can enter the device! Never immerse the device in water!

#### **Notice**

Do not operate the device without an inserted air filter!

Without the air filter, the inside of the device will be heavily contaminated. This could reduce the performance and result in damage to the device.

## Behaviour in the event of an emergency

1. Switch the device off.
2. Disconnect the device from the mains by removing the mains plug from the socket. When doing so, be sure to hold the plug, not the cable.
3. Do not reconnect a defective device to the mains.

## Information about the device

### Device description

The device serves the purpose of cooling the room air. It further filters and dehumidifies the air thus creating an agreeable room climate.

The device cools the room air by withdrawing warmth. The absorbed warmth is emitted to the outside via the exhaust air hose; cooled air is fed to the installation site by means of a fan.

Accumulating condensate drips from the evaporator onto the hot condenser, there it evaporates and then is transported to the outside via the exhaust air hose.

In *Ventilation* mode the device provides the opportunity of air circulation without cooling effect.

In *Dehumidification* mode moisture is withdrawn from the air.

The device operates fully automatically and features a variety of further options. The device can, for instance, be switched on or off automatically with time delay via the timer function.

Operation of the device is possible either via the control panel at the device or via the supplied infrared remote control.

The device was designed for universal and flexible application.

Due to its compact dimensions it can be easily transported and used in all interior spaces.

The device is not protected against water (IPX0).

**Device depiction**

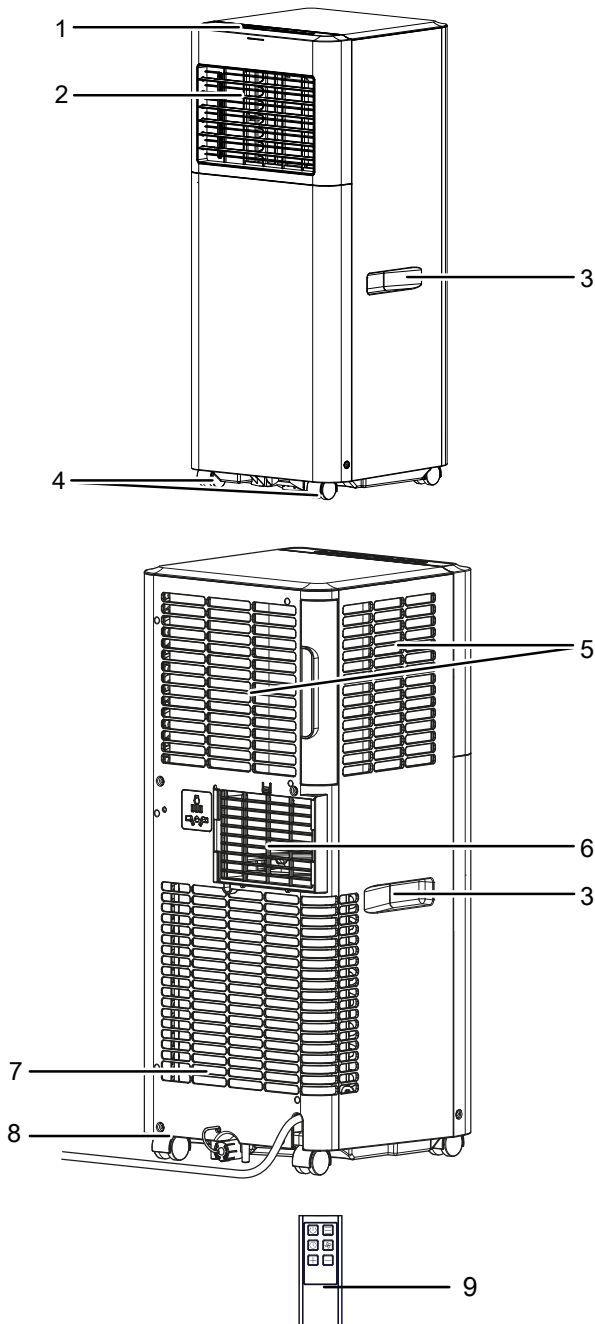

**Transport and storage**

**Notice**

If you store or transport the device improperly, the device may be damaged.  
 Note the information regarding transport and storage of the device.

**Transport**

Please note that additional transport regulations might apply to devices containing flammable refrigerants. The equipment's arrangement and the maximum number of components to be transported together can be gathered from the applicable transport regulations.

To make the device easier to transport, it is fitted with wheels.  
 To make the device easier to transport, it is fitted with a handle.

**Before** transporting the device, observe the following:

- Switch the device off.
- Disconnect the device from the mains by removing the mains plug from the socket. When doing so, be sure to hold the plug, not the cable.
- Drain the remaining condensate from the device.
- Do not use the power cable to drag the device.
- Only wheel the device on firm and level surfaces.

**After** transporting the device, proceed as follows:

- Set up the device in an upright position after transport.
- Leave the device to rest for at least 12 hours, so the refrigerant can accumulate within the compressor. Wait 12 hours before switching the device back on! Acting contrary might lead to compressor damage and a malfunctioning device.

No.	Designation
1	Control panel
2	Air outlet with adjustable ventilation flaps
3	Transport handle
4	Wheels
5	Air inlet with air filter
6	Exhaust air hose connection
7	Air inlet
8	Condensate outlet with rubber stopper
9	Remote control

## Storage

**Before** storing the device, observe the following:

- Drain the remaining condensate from the device.
- Disconnect the device from the mains by removing the mains plug from the socket. When doing so, be sure to hold the plug, not the cable.

When the device is not being used, observe the following storage conditions:

- Only store the device in a room measuring more than 7 m<sup>2</sup>.
- Store the appliance in a room without continuously operating open flames (for example an operating gas appliance) or other potential ignition sources (for example an operating electric heater, hot surfaces);
- Store the device in a dry location and protected from frost and heat.
- Store the device in an upright position where it is protected from dust and direct sunlight.
- If required, use a cover to protect the device from invasive dust.
- Place no further devices or objects on top of the device to prevent it from being damaged.
- Remove the batteries from the remote control.

## Assembly and start-up

### Scope of delivery

- 1 x Device
- 1 x Exhaust air hose
- 1 x Hose adapter
- 1 x Hose connector
- 1 x Remote control (without batteries)
- 1 x Manual

### Unpacking the device



#### Warning

There is a danger of suffocation for children due to packaging material! Keep packaging films and parts away from children. There is a risk of death due to suffocation.

1. Open the cardboard box and take the device out.
2. Completely remove the packaging.
3. Fully unwind the power cable. Make sure that the power cable is not damaged and that you do not damage it during unwinding.

## Start-up

When positioning the device, observe the minimum distance from walls or other objects as described in the Technical data chapter.

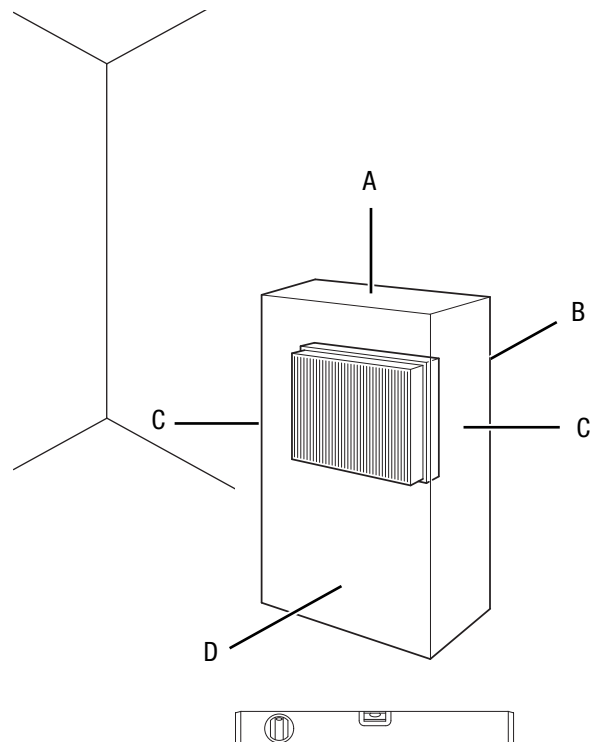

- Before restarting the device, check the condition of the power cable. If there are doubts as to the sound condition, contact the customer service.
- Only position the device in rooms where potentially leaking refrigerant cannot accumulate.
- Place the device in an upright and stable position on a horizontal and stable surface.
- Do not create tripping hazards when laying the power cable or other electric cables, especially when positioning the device in the middle of the room. Use cable bridges.
- Make sure that extension cables are completely unrolled.
- Keep air inlets and outlets as well as the exhaust air hose connection free.
- Make sure that no curtains or other objects interfere with the air flow.

### Inserting batteries into the remote control

#### Notice

Do not use rechargeable batteries! Observe the Technical data for start-up.

Please proceed as follows to insert or exchange the batteries:

1. Remove the battery cover from the rear of the remote control.
2. Insert two AAA batteries into the battery compartment adhering to the correct polarity.
3. Slide the battery cover back onto the remote control.

### Inserting the air filter

#### Notice

Do not operate the device without the air filters inserted! Without the air filter, the inside of the device will be heavily contaminated. This could reduce the performance and result in damage to the device.

- Make sure that the air filters are installed before switching the device on.

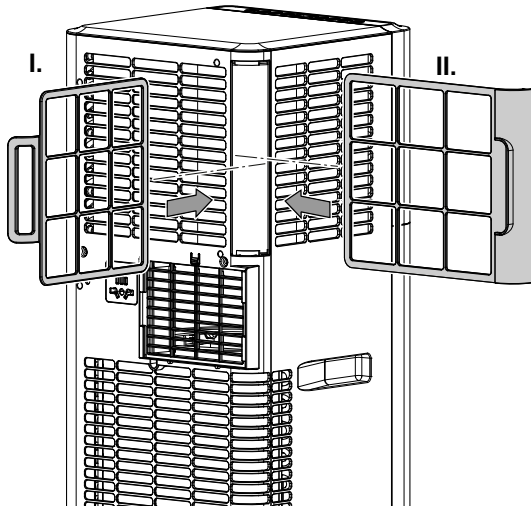

### Connecting the exhaust air hose

1. Connect the hose adapter and the hose connector to one end of the exhaust air hose each.

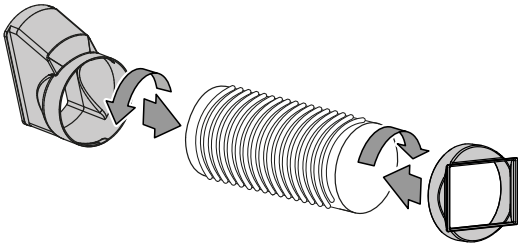

2. Connect the suitable end of the exhaust air hose to the exhaust air hose connection (6) located at the device.

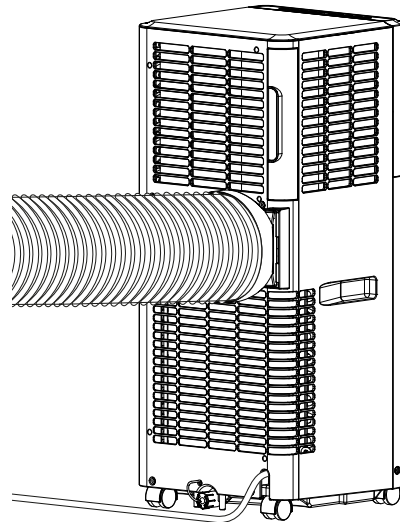
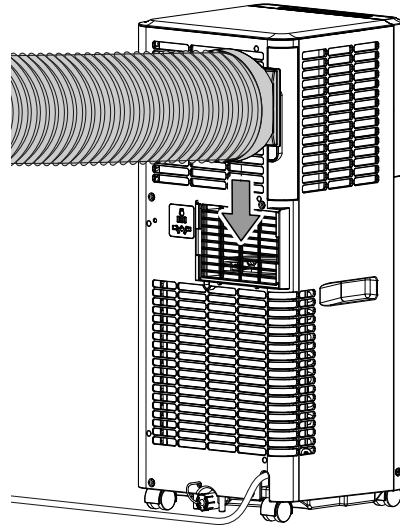

### Discharging exhaust air

- The exhaust air coming from the device contains waste heat from the room to be cooled. For this reason it is recommended to discharge the exhaust air to the outside.
- The end of the exhaust air hose can be fed through the open window. If required, secure the open window with the corresponding means, so that the end of the exhaust air hose cannot shift.
- The end of the exhaust air hose can also be hooked into a tilted window.

For this purpose, we recommend using a window seal (optional).

- Install the exhaust air hose inclined with the air direction.
- The connected hose must not contain any source of ignition.

*Example with exhaust air hose:*

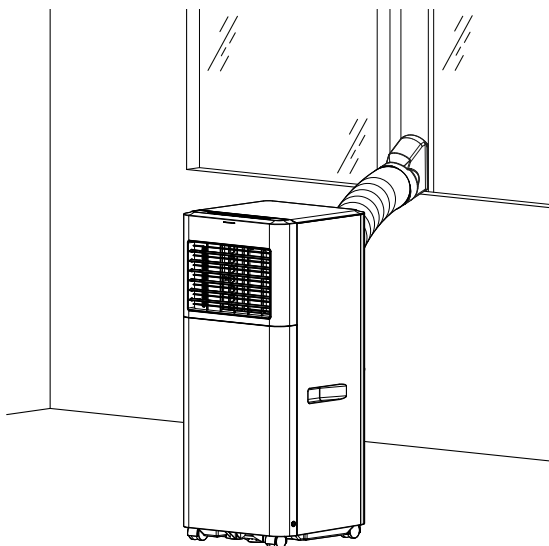

For installing the exhaust air hose please observe the following:

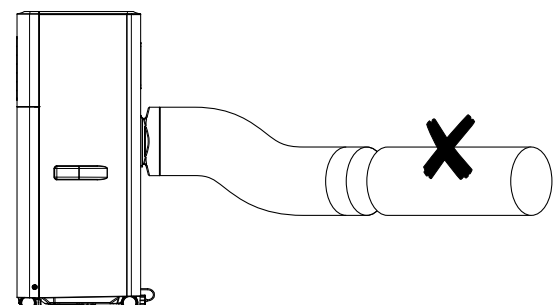
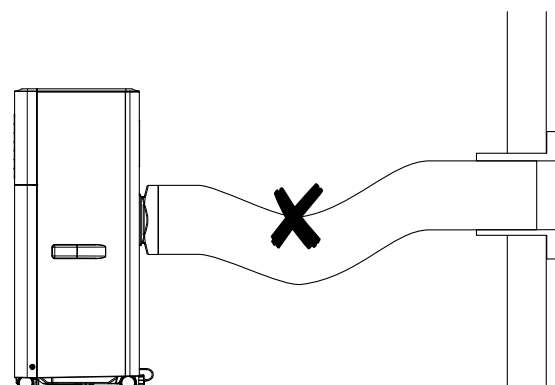
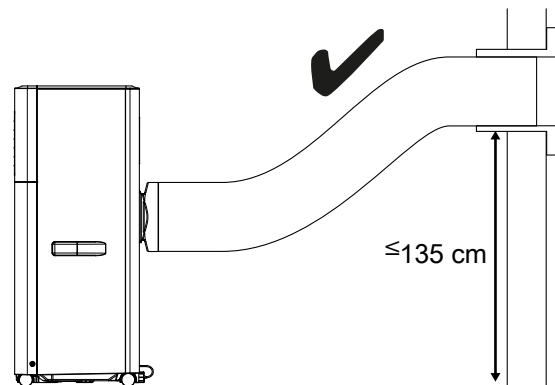
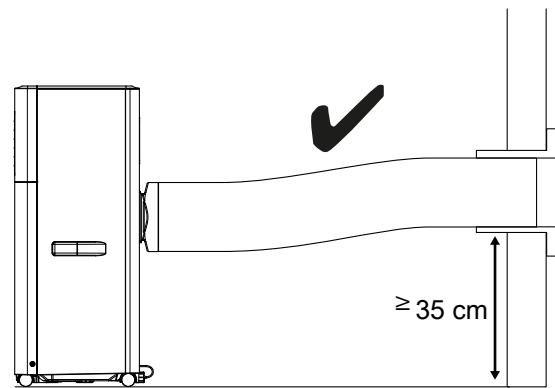

- Avoid kinks in the exhaust air hose. Kinks and bends would lead to an accumulation of emitted humid air causing the device to overheat and shut down.
- The dimensions of the exhaust air hose were especially made to fit the device. Do not replace or extend the hose. This could cause a malfunction of the device.

**Opening the ventilation flaps**

- Prior to switching the device on, open the horizontal ventilation flaps at the air outlet. Adjust the horizontal ventilation flaps to the desired position.

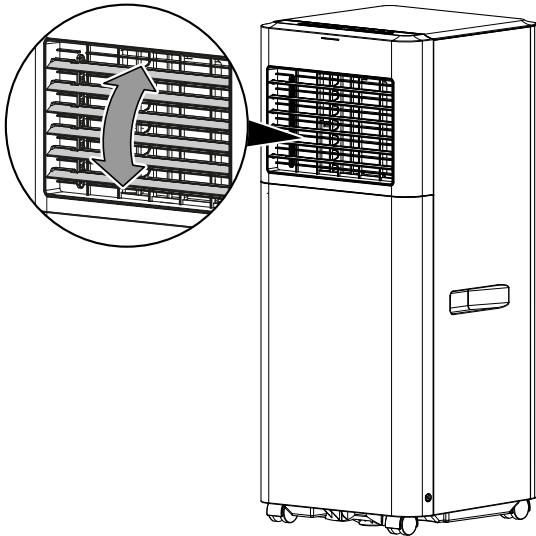

**Connecting the power cable**

- Connect the mains plug to a properly secured socket.

**Operation**

- Avoid open doors and windows.

**Operating elements**

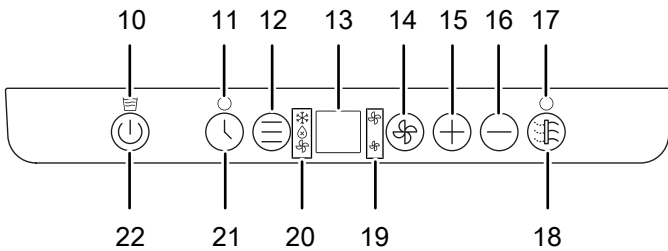

**Remote control**

All settings of the device can also be made using the remote control included in the scope of delivery.

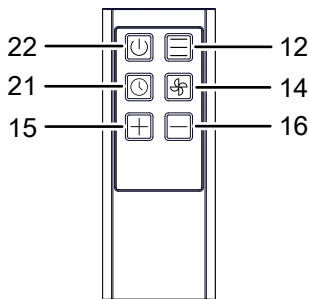

No.	Designation	Meaning
10	Water filling level LED	Empty condensation tray indication
11	Timer LED	Illuminated when the timer is activated
12	Operating mode button	Selecting the operating mode: <i>Cooling</i> <i>Dehumidification</i> <i>Ventilation</i>
13	Segment display	Indication of the target temperature and current room temperature Indication of the set number of hours during timer programming Indication of the error code, see chapter Errors and faults
14	Fan speed button	Setting the fan speed
15	Up button	Setting the target temperature for cooling between 16 °C and 32 °C Setting the number of hours for the timer in increments of 1 hour (1 h to 24 h)
16	Down button	
17	Filter LED	Illuminated when the filters need to be cleaned/changed
18	Filter button	Resetting the filter status
19	Fan speed LEDs	Fan speed indication: ☼ = high (stage 2) ☼ = low (stage 1)
20	Operating mode LEDs	Indicates the selected operating mode: ❄ = <i>Cooling</i> 💧 = <i>Dehumidification</i> ☼ = <i>Ventilation</i>
21	Timer button	Switching the timer functions on or off
22	Power button	Switching the device on or off



**Warning of electrical voltage**

Risk of electric shock!

The device is not protected against water.

There is a risk of electric shock!

Never use the device in areas where dripping, spraying or running water can enter the device! Never immerse the device in water!



**Info**

An acoustic signal is emitted each time a setting is activated.

## Switching the device on

1. Once you have completely installed the device as described in the Start-up chapter, you can switch it on.
2. Press the *Power* button (22).
  - ⇒ The device starts in cooling mode.
  - ⇒ The *Cooling* LED is illuminated.
  - ⇒ The *Fan speed* LED is illuminated.
3. Select the desired operating mode.

The device switches off automatically when the condensation tray is full. The *Water filling level* LED (10) is illuminated.

## Setting the operating mode

The device has the following operating modes:

- Cooling
- Dehumidification
- Ventilation

## Cooling

In *Cooling* mode the room will be cooled down to the desired target temperature.

1. Press the *Operating mode* button (12) until the *Cooling* LED (20) is illuminated.
2. Repeatedly press the *Up* (15) or *Down* (16) button to select the desired target temperature. The temperature can be adjusted in increments of 1 °C in a range between 16 °C and 32 °C.
  - ⇒ The segment display (13) briefly indicates the desired target temperature, then the current room temperature appears.
3. Press the *Fan speed* button (14) to set the desired fan stage.
  - ⇒ The *Fan speed* LED (19) for the desired fan stage will be illuminated.

## Dehumidification

In *Dehumidification* mode the humidity level in the room is reduced.



### Info

During *Dehumidification* mode, the exhaust air hose must be connected so that the condensate can escape from the room to be dehumidified.

1. Press the *Operating mode* button (12) until the *Dehumidification* LED (20) is illuminated.
  - ⇒ *Dehumidification* mode is selected.
  - ⇒ The fan stage cannot be adjusted at a room temperature of up to 25 °C. The ventilation runs at minimum speed. If the room temperature is above 25 °C, you can set the fan stage manually.



### Info

If the device is operated in a very humid environment, the accumulating condensate must be discharged at regular intervals (see *Condensate discharge*).

## Ventilation



### Info

Remove the exhaust air hose during *Ventilation*.

In *Ventilation* mode the room air is circulated, it will neither be cooled nor dehumidified.

1. Press the *Operating mode* button (12) until the LED for *Ventilation* (20) lights up.
2. Press the *Fan speed* button (14) to set the desired fan speed.
  - ⇒ The LED for the selected fan speed (19) will be illuminated.

## Setting the timer

The timer function switches the device on or off after the set time has elapsed. This setting can be made at the device or using the remote control and set in all operating modes.

The time can be set in increments of 1 hour (1 h to 24 h).

✓ **Automatic switch-on:** The device is in standby mode.

✓ **Automatic switch-off:** The device is switched on.

1. Press the *Timer* button (21).
  - ⇒ The *Timer* LED (11) is illuminated.
  - ⇒ The number of hours flashes on the segment display (13) for approx. 10 seconds.
2. Repeatedly press the *Up* (15) or *Down* (16) button to select the desired number of hours until automatic switch-off.
3. Press the *Timer* button (21) to confirm the setting.
  - ⇒ The segment display (13) continuously indicates the number of hours until automatic switch-on or switch-off.
  - ⇒ The *Timer* LED (11) is illuminated as long as the timer is active.
  - ⇒ After the predefined time, the device switches itself on or off.
  - ⇒ Setting the number of hours to 0 switches the timer function off.
  - ⇒ If the device is disconnected from the power supply, all settings for automatic switch-on/switch-off are deleted.

## Shutdown

- Switch the device to standby mode by pressing the *Power* button (22).
- Disconnect the device from the mains by removing the mains plug from the socket. When doing so, be sure to hold the plug, not the cable.
- Empty the condensation tray if necessary.
- If necessary, remove the condensation drain hose and any residual fluid from it.
- If required, clean the device according to the "Maintenance" chapter.
- Store the device according to the *Transport and storage* chapter.

## Errors and faults

The device has been checked for proper functioning several times during production. If malfunctions occur nonetheless, check the device according to the following list.

### Notice

Wait for at least 3 minutes after maintenance and repair work. Only then switch the device back on.

### The device does not start:

- Check the power connection.
- If the device has been switched off, it cannot be switched on for the next 3 minutes.
- Check the power cable and mains plug for damage. If you notice damages, do not try to take the device back into operation.  
If the supply cord is damaged, it must be replaced by the manufacturer, its service agent or similarly qualified persons in order to avoid a hazard.
- Check the on-site fusing.
- Observe the operating temperature according to the chapter Technical annex.
- The condensation tray may be full. Empty the condensation tray when the *Water filling level* LED (10) is illuminated.
- If the device is not starting, have the electricians checked by a specialist company or by the manufacturer.

### The device works with reduced or no cooling capacity:

- Check whether *cooling* mode is selected.
- Check the position of the ventilation flaps. They must be opened to the maximum.
- Check the air filter(s) for dirt. If necessary, clean or replace the air filter(s).
- Check the minimum distance to walls or other objects. Position the device a little more in the room's centre if required.
- Check the temperature setting at the device. Reduce the set temperature if it is higher than the room temperature.

### The device is loud or vibrates:

- Check whether the device is set up in a stable and upright position.

### Condensate is leaking:

- Check the device for leaks.

### The compressor does not start:

- Check whether the overheating protection of the compressor has tripped. Disconnect the device from the mains and let it cool down for approx. 10 minutes before reconnecting it.
- The compressor may start up with a delay of 3 minutes, as it is provided with an internal protection against direct restart.

### The device gets very warm, is loud or is losing power:

- Check the air inlet and air filter for dirt. Remove external dirt.
- From the outside, check the device for dirt (see chapter Maintenance). If the inside of the device is dirty, have it cleaned by a specialist company for cooling and air-conditioning or by the manufacturer.

### The device does not respond to the infrared remote control:

- Check whether the distance between remote control and device is too large and reduce it if necessary.
- Make sure there are no obstacles, such as furniture or walls, between the device and the remote control. Ensure visual contact between device and remote control.
- Check the charging status of the batteries and change them if required.
- If the batteries have just been changed, check them for correct polarity.

### The device still does not operate correctly after these checks:

Please contact the customer service. If necessary, bring the device to a specialist company for cooling and air-conditioning or to the manufacturer for repair.

### Error codes

The following error messages can be displayed on the segment display (13):

Error code	Cause	Remedy
E1	Error at the room temperature sensor	Disconnect the device briefly from the mains. Should the error still be displayed after the restart, please contact the customer service.
E2	Error at the temperature sensor of the evaporator	Disconnect the device briefly from the mains. Should the error still be displayed after the restart, please contact the customer service.

## Maintenance

## Maintenance intervals

Maintenance and care interval	before every start-up	as needed	at least every 2 weeks	at least every 4 weeks	at least every 6 months	at least annually
Check air inlets and outlets for dirt and foreign objects and clean if necessary	X			X		
Clean the exterior		X				X
Visually check the inside of the device for dirt		X				X
Check the air filter for dirt and foreign objects and clean or replace if necessary	X		X			
Replace the air filter					X	
Check for damage	X					
Check the attachment screws		X				X
Test run						X
Empty the condensation tray and drain hose		X				

## Maintenance and care log

Device type: .....

Device number: .....

Maintenance and care interval	1	2	3	4	5	6	7	8	9	10	11	12	13	14	15	16
Check air inlets and outlets for dirt and foreign objects and clean if necessary																
Check air inlets and outlets for dirt and foreign objects and clean if necessary																
Clean the exterior																
Visually check the inside of the device for dirt																
Replace the air filter																
Check the attachment screws																
Test run																
Empty the condensation tray and drain hose																
Comments																

1. Date: ..... Signature: .....	2. Date: ..... Signature: .....	3. Date: ..... Signature: .....	4. Date: ..... Signature: .....
5. Date: ..... Signature: .....	6. Date: ..... Signature: .....	7. Date: ..... Signature: .....	8. Date: ..... Signature: .....
9. Date: ..... Signature: .....	10. Date: ..... Signature: .....	11. Date: ..... Signature: .....	12. Date: ..... Signature: .....
13. Date: ..... Signature: .....	14. Date: ..... Signature: .....	15. Date: ..... Signature: .....	16. Date: ..... Signature: .....

**Activities required before starting maintenance**



**Warning of electrical voltage**

Do not touch the mains plug with wet or damp hands.

- Switch the device off.
- Disconnect the device from the mains by removing the mains plug from the socket. When doing so, be sure to hold the plug, not the cable.



**Warning of electrical voltage**

Tasks which require the device to be opened must only be carried out by authorised specialist companies or by the manufacturer.

**Refrigerant circuit**



**Danger**

**Natural refrigerant propane (R290)!**

- H220 – Extremely flammable gas.
- H280 – Contains gas under pressure; may explode if heated.
- P210 – Keep away from heat, sparks, open flames and other ignition sources. No smoking.
- P377 – Leaking gas fire: Do not extinguish, unless leak can be stopped safely.
- P410+P403 – Protect from sunlight. Store in a well-ventilated place.

- The entire refrigerant circuit is a maintenance-free, hermetically sealed system and may only be maintained or repaired by specialist companies for cooling and air-conditioning or by the manufacturer.

**Safety signs and labels on the device**

Check the safety signs and labels attached to the device at regular intervals. Replace illegible safety signs!

**Cleaning the housing**

Clean the housing with a soft, damp and lint-free cloth. Make sure that no moisture enters the housing. Protect electrical components from moisture. Do not use any aggressive cleaning agents such as cleaning sprays, solvents, alcohol-based or abrasive cleaners to dampen the cloth.

**Visual inspection of the inside of the device for dirt**

1. Remove the air filters.
2. Use a torch to illuminate the openings of the device.
3. Check the inside of the device for dirt.
4. If you see a thick layer of dust, have the inside of the device cleaned by a specialist company for cooling and air-conditioning or by the manufacturer.
5. Reinsert the air filters.

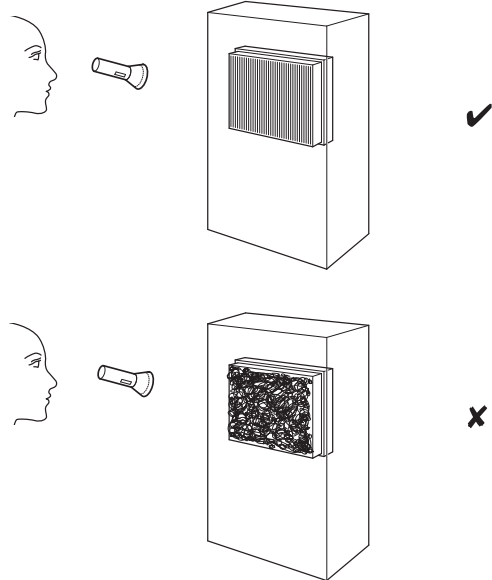

## Cleaning the air filter

The air filters must be cleaned regularly, every 500 operating hours under normal use. If the *Filter* LED (17) is illuminated, the filters need to be cleaned. This ensures full device performance. When used in dusty surroundings, clean the filters every 2 weeks.

### Warning

Ensure that the air filters are neither worn nor damaged. The corners and edges of the air filters must not be deformed or rounded. Before reinserting the air filters, make sure that they are undamaged and dry!

1. Remove the air filters from the device.

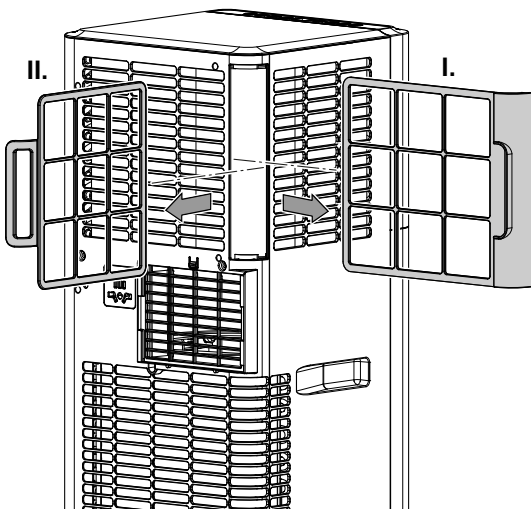

## Condensate discharge (manual draining)

In *Cooling* and *Dehumidification* mode condensate is formed, which is mostly discharged via the exhaust air.

The remaining condensate is collected in a condensation tray within the housing. The condensate must be drained regularly.

1. Check whether there is a drain at the installation site or provide a suitable collection container under the condensate outlet.

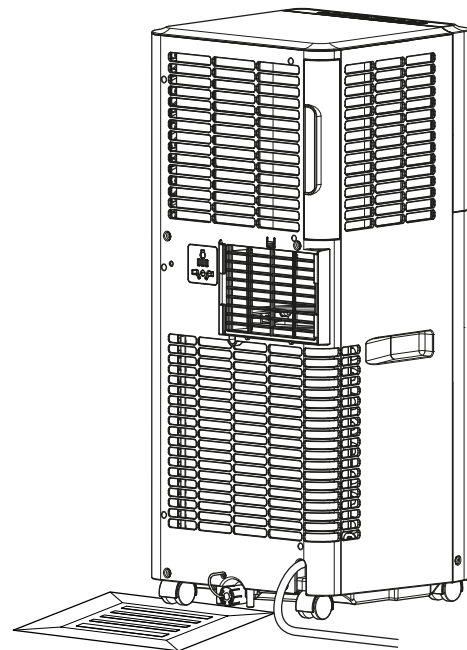

2. Clean the filters using a slightly damp, soft, lint-free cloth. If the filters are heavily contaminated, clean them with warm water mixed with a neutral cleaning agent.
3. Allow the filters to dry completely. Do not put any wet filters into the device!
4. Reinsert the air filters into the device.

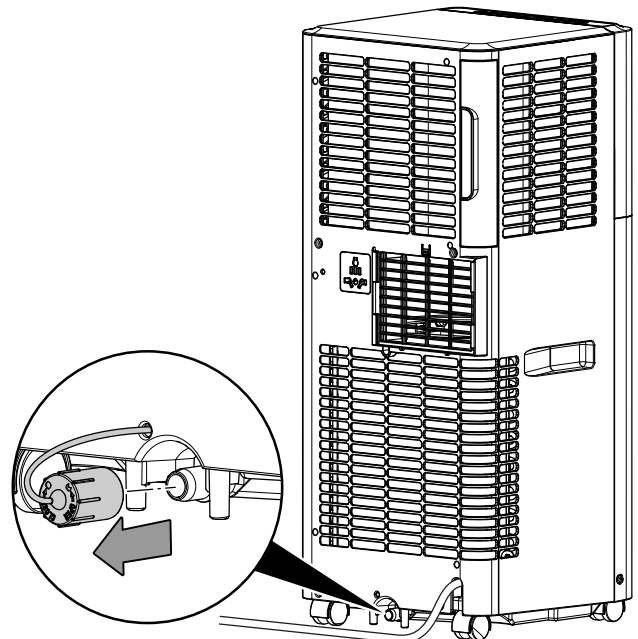
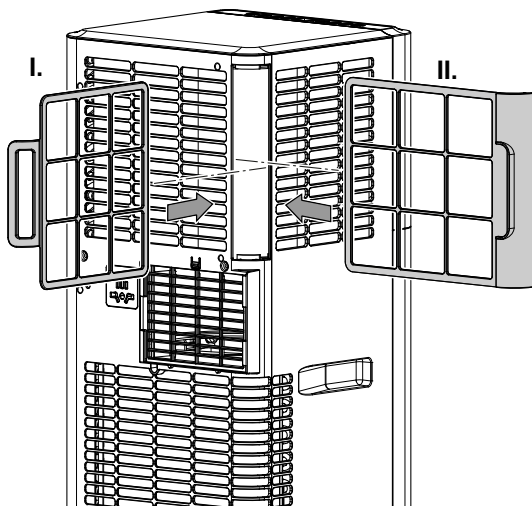

2. Drain the condensate.

5. Press the *Filter* button (18) to reset the filter status.

3. Reattach the rubber stopper to the condensate outlet. Ensure the tight fit of the rubber stopper, for otherwise there might be uncontrolled water leakage.

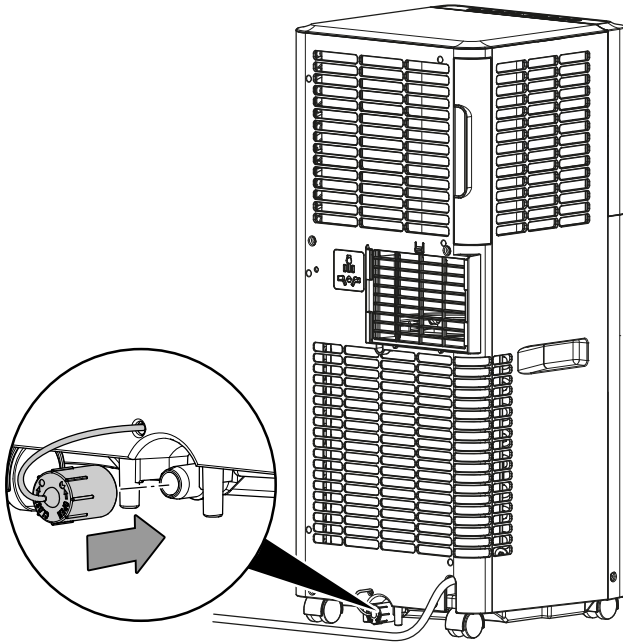

⇒ The *Water filling level* LED (10) will go out as soon as the condensate has been drained.

### Activities required after maintenance

If you want to continue using the device:

- If the device has been switched off, it cannot be switched on for the next 3 minutes.
- Leave the device to rest for at least 12 hours if it has been tilted by more than 45° during maintenance. During this time, the lubricating oil can be returned to the compressor. Wait 12 hours before switching the device back on! Acting contrary might lead to compressor damage and a malfunctioning device.

If you do not intend to use the device for a considerable time:

- Store the device according to the Transport and storage chapter.

**Technical annex**
**Technical data**

Model	PAC 2015 E
Cooling capacity	2 kW
Dehumidification performance	1.9 l/h
Operating temperature	16 °C to 35 °C
Temperature setting range	16 °C to 32 °C
Max. air volume flow	300 m <sup>3</sup> /h
Mains connection	220 V – 240 V / 50 Hz
Nominal current	3.2 A
Fusing 	T 3.15 A 250 V
Type of protection	IPX0
Max. power consumption	770 W
Sound pressure level at a distance of 1 m	55 dB(A)
Refrigerant	R290
Amount of refrigerant	128 g
GWP factor	0.02
CO <sub>2</sub> equivalent	0.00000256 t
Suction side pressure	1.2 MPa
Discharge side pressure	2.4 MPa
Max. permissible pressure	2.6 MPa
Dimensions (length x width x height)	280 x 284 x 675 mm
Minimum distance to walls and other objects:	top (A): 30 cm rear (B): 30 cm sides (C): 30 cm front (D): 30 cm
Weight	19.5 kg
Remote control batteries	Type LR03 / AAA – 1.5 V (2 pcs.)

**Circuit diagram**

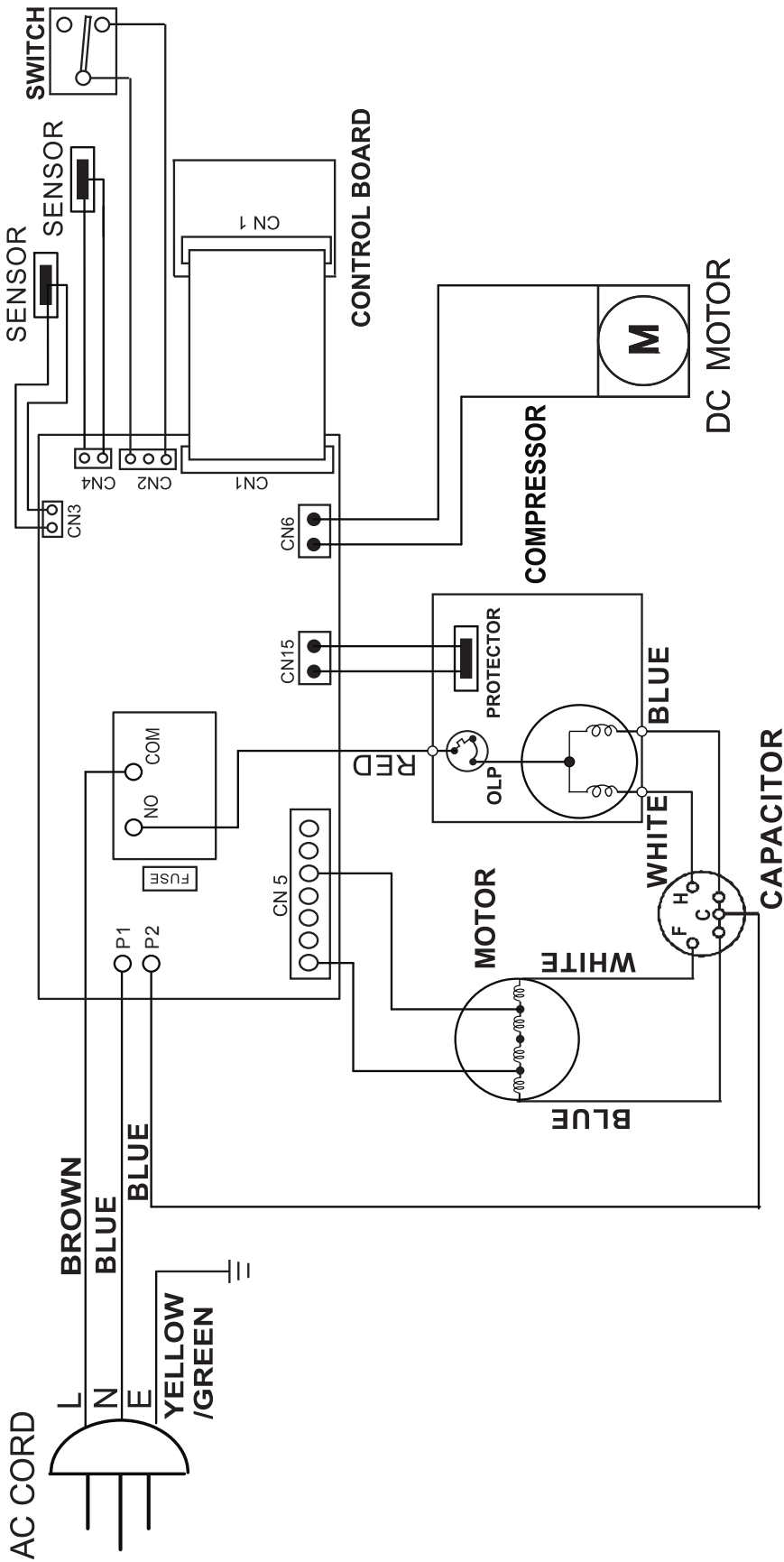

## Overview and list of spare parts

**Note:** The position numbers of the spare parts differ from those describing the positions of the components mentioned in these instructions.

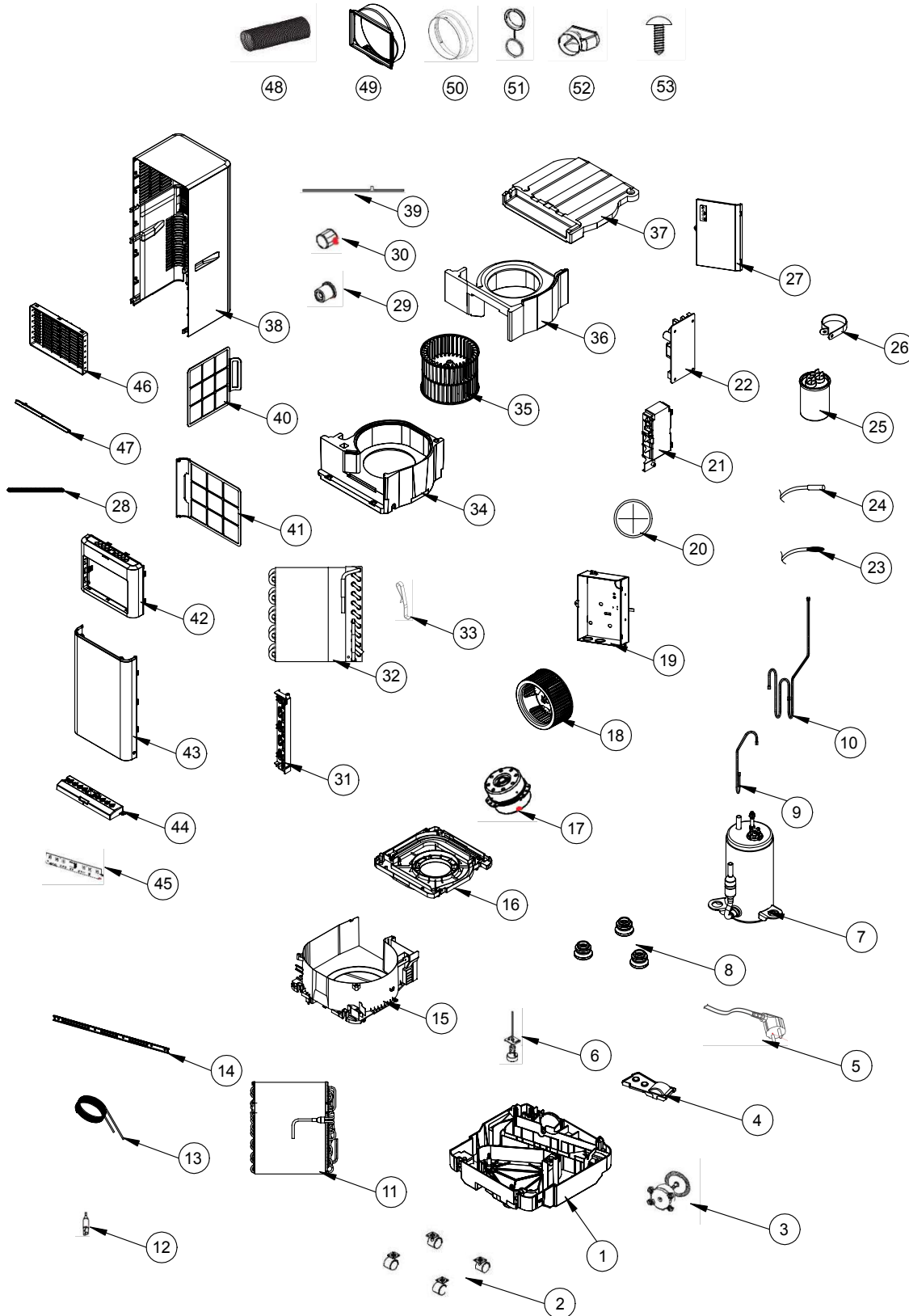

No.	Spare part	Quantity	No.	Spare part	Quantity	No.	Spare part	Quantity
1	BASE PAN	1	19	ELECTRICAL BOX	1	37	TOP COVER PLATE	1
2	TURING WHEEL	4	20	SHEATH	3	38	REAR PANEL	1
3	FAN MOTOR	1	21	FIX TURE	1	39	BAND	1
4	COVER	1	22	CONTROL BOARD	1	40	AIR FILTER	1
5	POWER SUPPLY CORD COMPLETE	1	23	SENSOR (FOR INDOOR)	1	41	AIR FILTER	1
6	SWITCH	1	24	SENSOR (FOR EVAPORATOR)	1	42	FRONT PANEL	1
7	COMPRESSOR ASS'Y (39H063-D1)	1	25	CAPACITOR (30 uF/450V+4 uF/450 V)	1	43	FRONT PANEL	1
8	RUBBER	3	26	FIX METAL	1	44	FIX TURE	1
9	DISCHARGE PIPE	1	27	COVER	1	45	PC BOARD	1
10	SUCTION PIPE	1	28	CONNECTING ROD	1	46	DISCHAR GELLE	1
11	CONDENSER ASS'Y	1	29	SOFT CAP	1	47	VAN AIR DEFLEETOR	6
12	Y TUBE	1	30	PLUG	1	48	HEAT EXHAUST HOSE	1
13	CAPILARY TUBE	1	31	PLATE	1	49	HEAT EXHAUST HOSE CONNECTOR	1
14	STRIKE	2	32	EVAPORATOR ASS'Y	1	50	HEAT EXHAUST HOSE CONNECTOR	1
15	FAN CASING	1	33	FIX METAL	1	51	FIX TURE	1
16	FAN CASING	1	34	FAN CASING	1	52	DISCHAR GELLE	1
17	FAN MOTOR (SA(AL)46C)	1	35	BLOWER WHEEL	1	53	SCREW	3
18	BLOWER WHEEL	1	36	FAN CASING	1			

## Disposal

Always dispose of packing materials in an environmentally friendly manner and in accordance with the applicable local disposal regulations.



The icon with the crossed-out wheeled bin indicates that this device and any associated components (e.g. remote controls) must not be disposed of with household waste at the end of their life, in accordance with the Waste Electrical and Electronic Equipment Directive (2012/19/EU) and national laws.

You will find collection points for free return of waste electrical and electronic equipment in your vicinity. The addresses can be obtained from your municipality or local administration. You can also find out about other return options that apply for many EU countries on the website <https://hub.trotec.com/?id=45090>. Otherwise, please contact an official recycling centre for electronic and electrical equipment authorised for your country.

The separate collection of waste electrical and electronic equipment aims to enable the re-use, recycling and other forms of recovery of waste equipment as well as to prevent negative effects for the environment and human health caused by the disposal of hazardous substances potentially contained in the equipment.



This icon with the crossed-out wheeled bin indicates that batteries or accumulators must not be disposed of with household waste at the end of their life. If the device contains batteries or accumulators that contain mercury, cadmium or lead, the respective chemical symbol (Hg, Cd or Pb) is shown below the icon of the crossed-out wheeled bin. To prevent environmental pollution, do not carelessly leave batteries or electrical and electronic equipment containing batteries in public areas. In the European Union, batteries and accumulators must be returned to a designated collection point in accordance with REGULATION (EU) 2023/1542 OF THE EUROPEAN PARLIAMENT AND OF THE COUNCIL of 12 July 2023 concerning batteries and waste batteries. Remove batteries/accumulators and dispose of them separately according to the relevant legal requirements.

Have the refrigerant (propane) disposed of appropriately and according to the national regulations by a company with the relevant certification (European Waste Catalogue 160504).

## Only for United Kingdom

According to Waste Electrical and Electronic Equipment Regulations 2013 (SI 2013/3113) (as amended) and the Waste Batteries and Accumulators Regulations 2009 (SI 2009/890) (as amended), devices that are no longer usable must be collected separately and disposed of in an environmentally friendly manner.

Trotec GmbH

Grebbener Str. 7  
52525 Heinsberg  
Germany

☎ +49 2452 962-0

☎ +49 2452 962-200

✉ [online@trotec.com](mailto:online@trotec.com)

[www.trotec.com](http://www.trotec.com)