

# IDE 20 / IDE 30 / IDE 50 / IDE 60 / IDE 80

EN

ORIGINAL INSTRUCTIONS  
OIL HEATER



**Table of contents**

**Notes regarding the instructions** ..... 2

**Safety** ..... 3

**Information about the device** ..... 5

**Transport and storage** ..... 7

**Assembly and start-up** ..... 7

**Operation** ..... 12

**Available accessories** ..... 15

**Errors and faults** ..... 16

**Maintenance** ..... 19

**Technical annex** ..... 21

**Disposal** ..... 30

**Declaration of conformity** ..... 30

**Notes regarding the instructions**

**Symbols**

 **Warning of electrical voltage**  
This symbol indicates dangers to the life and health of persons due to electrical voltage.

 **Warning of flammable substances**  
This symbol indicates dangers to the life and health of persons due to flammable substances.

 **Warning of hot surface**  
This symbol indicates dangers to the life and health of persons due to hot surface.

 **Warning**  
This signal word indicates a hazard with an average risk level which, if not avoided, can result in serious injury or death.

 **Caution**  
This signal word indicates a hazard with a low risk level which, if not avoided, can result in minor or moderate injury.

**Note**  
This signal word indicates important information (e.g. material damage), but does not indicate hazards.

 **Info**  
Information marked with this symbol helps you to carry out your tasks quickly and safely.



**Follow the manual**

Information marked with this symbol indicates that the instructions must be observed.



**Wear hearing protection**

Information marked with this symbol indicates that you should wear hearing protection.

You can download the current version of these instructions via the following link:

IDE 20



<https://hub.trotec.com/?id=39787>

IDE 30



<https://hub.trotec.com/?id=42316>

IDE 50



<https://hub.trotec.com/?id=42317>

IDE 60



<https://hub.trotec.com/?id=42318>

IDE 80



<https://hub.trotec.com/?id=42319>

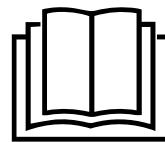

## Safety

**Read this manual carefully before starting or using the device. Always store the manual in the immediate vicinity of the device or its site of use.**



### Warning

**Read all safety warnings and all instructions.**

Failure to follow the warnings and instructions may result in electric shock, fire and/or serious injury.

**Save all warnings and instructions for future reference.**

This device must not be used by children and persons under 16 years of age.

Children shall not play with the appliance. Cleaning and user maintenance shall not be made by children under 16 years.



### Warning

Do not use the device in rooms if persons are present who cannot leave the room independently and who are not under constant supervision.

- Do not use the device in potentially explosive rooms or areas and do not install it there.
- Do not use the device in aggressive atmosphere.
- Only put up the device in an upright, stable position on firm ground.
- Let the device dry out after a wet clean. Do not operate it when wet.
- Do not use the device with wet or damp hands.
- Do not expose the device to directly squirting water.
- Never insert any objects or limbs into the device.
- Do not cover the device during operation.
- Do not remove any safety signs, stickers or labels from the device. Keep all safety signs, stickers and labels in legible condition.
- Attention: In Germany, the Federal Emission Protection Directive applies. Do not operate the device for more than 3 months at the same place. Prior to planning the flue gas system, gather information about the national legislation and contact a responsible specialist.
- Do not sit on the device.
- This appliance is not a toy. Keep away from children and animals.
- Check accessories and connection parts for possible damage prior to every use of the device. Do not use any defective devices or device parts.
- Ensure that all electric cables outside of the device are protected from damage (e.g. caused by animals). Never use the device if electric cables or the power connection are damaged!

- The mains connection must correspond to the specifications in the Technical annex.
- Insert the mains plug into a properly fused mains socket.
- Observe the device's power input, cable length and intended use when selecting extensions to the power cable. Completely unroll extension cables. Avoid electrical overload.
- Before carrying out maintenance, care or repair work on the device, remove the mains plug from the mains socket. Hold onto the mains plug while doing so.
- Switch the device off and disconnect the power cable from the mains socket when the device is not in use.
- When positioning the device, observe the minimum distances from walls and other objects as well as the storage and operating conditions specified in the Technical annex.
- Make sure that the air inlet and outlet are not obstructed.
- Make sure that the suction side is kept free of dirt and loose objects.
- Do not place the device on combustible ground.
- Only transport the device in an upright position.
- Only use original spare parts, for otherwise safe and functional operation cannot be ensured.
- Do not use the heating device together with a programming device, a timer, a separate remote control system or any other device that automatically switches the heating device on, as there is a risk of fire if the heating device is covered or incorrectly positioned.

### Intended use

The device was developed for the purpose of generating hot air and may only be used in roofed over outdoor areas or in well-ventilated interior spaces whilst adhering to the technical data.

The device is suited for heating large rooms such as tents, warehouses, workshops, construction sites, greenhouses or agricultural halls.

It is intended to be used without frequent site changes.

The device may only be used in rooms with sufficient fresh air supply and exhaust discharge.

The device must only be operated with EL (ultra-light) fuel oil, kerosene and diesel, however not with petrol, heavy fuel oil etc.

Any use other than the intended use is regarded as misuse.

**Reasonably foreseeable misuse**

- Do not use the heating device in immediate proximity to swimming pools.
- Do not place any objects, e.g. clothing, on the device.
- Do not use this device in the vicinity of fuel, solvents, varnishes or other easily inflammable vapours or in rooms where these substances are stored.
- Do not use the device in areas with a fire hazard or in potentially explosive areas.
- Do not use the device out of doors, unless under a roof.
- Do not operate the device in rooms without sufficient combustion air supply.
- Never immerse the device in water.
- Do not make any unauthorised modifications, alterations or structural changes to the device.

**Personnel qualifications**

People who use this device must:

- be aware of the dangers resulting from heat, fire hazard and insufficient ventilation when working with oil heaters.
- be aware of the dangers that occur when handling fuels such as EL fuel oil, diesel or kerosene
- have read and understood the instructions, especially the Safety chapter.

**Safety devices**

The device is equipped with an electronic flame and maximum temperature monitoring system working with a photo cell and a safety thermostat.

The electronic control unit regulates the start-up, stopping and safety shutdown times in case of malfunctions.

**Personal protective equipment**



**Wear hearing protection**

Wear appropriate hearing protection when working with the device.

**Residual risks**



**Warning of electrical voltage**

Work on the electrical components must only be carried out by an authorised specialist company!



**Warning of electrical voltage**

Before any work on the device, remove the mains plug from the mains socket!  
Do not touch the mains plug with wet or damp hands. Hold onto the mains plug while pulling the power cable out of the mains socket.



**Warning of electrical voltage**

Risk of electric shock!  
Risk of an electric shock if the heating device comes into contact with water in swimming pools!  
Do not install the heating device in immediate proximity to swimming pools!



**Warning of flammable substances**

Handling fuels entails a risk of fire.  
Take sufficient precautions when handling fuels such as EL fuel oil, diesel or kerosene.  
Do not spill any fuels! Do not inhale the vapours nor swallow any fuel! Avoid skin contact!



**Warning of hot surface**

Parts of the device, especially at the air outlet, become very hot during operation. There is a danger of burning and fire. Do not touch the device during operation!  
During operation observe a safety distance of at least 2 m to the device front! Observe the minimum distance from walls or other objects according to the technical data!



**Warning of hot surface**

Parts of this appliance can become very hot and cause burns. Particular attention is to be paid when there are children or vulnerable persons present!



**Warning of hot surface**

Improper handling entails a risk of burning. Use this appliance only as described in this operating instructions.



**Warning**

Improper handling entails a risk of electric shock. Only use the device as intended!



**Warning**

Dangers can occur at the device when it is used by untrained people in an unprofessional or improper way! Observe the personnel qualifications!



**Warning**

The device is not a toy and does not belong in the hands of children.



**Warning**

Risk of suffocation!  
Do not leave the packaging lying around. Children may use it as a dangerous toy.



**Warning**

Improper installation entails a risk of fire.  
Do not place the device on combustible ground.  
Do not place the device on high-pile carpets.



### Warning

The device must not be covered, there is an imminent fire hazard!

### Behaviour in the event of an emergency

1. In an emergency, disconnect the device from the mains feed-in: Switch the device off and disconnect it from the mains.
2. Remove persons from the danger area.
3. Do not reconnect a defective device to the mains.

### Overheating protection

The device is provided with a safety thermostat which is activated by overheating of the device (when exceeding the operating temperature).

Investigate the cause of overheating.

If the safety thermostat does not switch in the event of overheating, the overheating protection will be tripped. In that case the device switches off completely. If so, please contact the customer service to have the overheating protection replaced.

## Information about the device

### Device description

The indirectly fired oil heaters IDE 20, IDE 30, IDE 50, IDE 60 and IDE 80 serve the purpose of heating the room air so as to quickly heat large rooms.

The devices only run on EL fuel oil or diesel, they must not be used with petrol, heavy fuel oil etc.

The devices are oil heaters with indirect combustion to be installed in roofed outdoor areas or in rooms with a sufficient fresh air supply. The devices are equipped with an exhaust gas connection for the discharge of exhaust gases via the chimney.

The devices IDE 30, IDE 50, IDE 60 and IDE 80 are additionally equipped with a fuel filter and a Danfoss pump.

### Functional principle

The device generates warmth by conveying the sucked-in, cold air past the enlarged area of the combustion chamber, the heat exchanger. The air to be heated is completely isolated from the combustion chamber, where the fuel is burned. The combustion products are discharged into the open air through a flue pipe. The sucked-in air is heated and fed back to the environment via the air outlet.

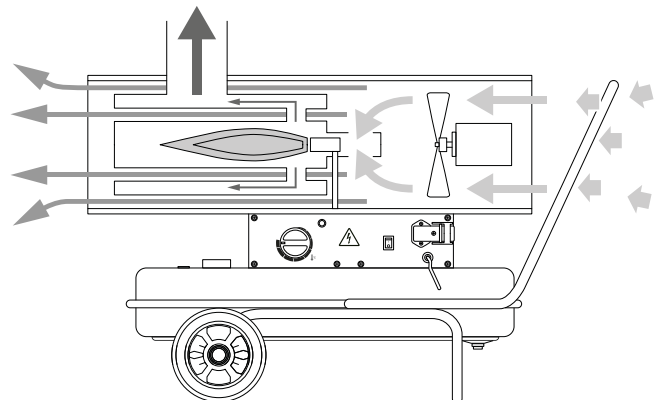

**Device depiction**

**IDE 20**

The side view of the operating elements shows the device IDE 20 by way of example.

**IDE 30 / IDE 50 / IDE 60 / IDE 80**

In addition, the devices IDE 30, IDE 50, IDE 60 and IDE 80 come with a fuel filter located at the side. The fuel tank cap (10) and the tank filling level indication (11) of the devices IDE 50, IDE 60 and IDE 80 are located at the rear.

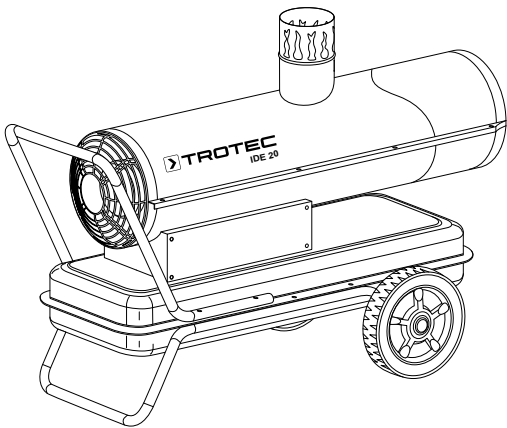
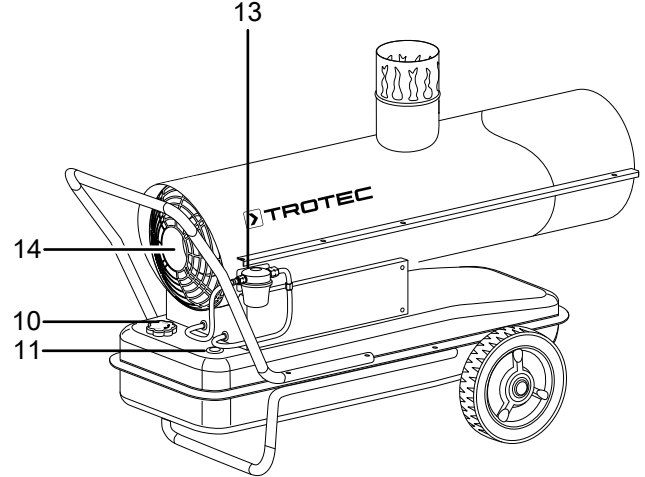
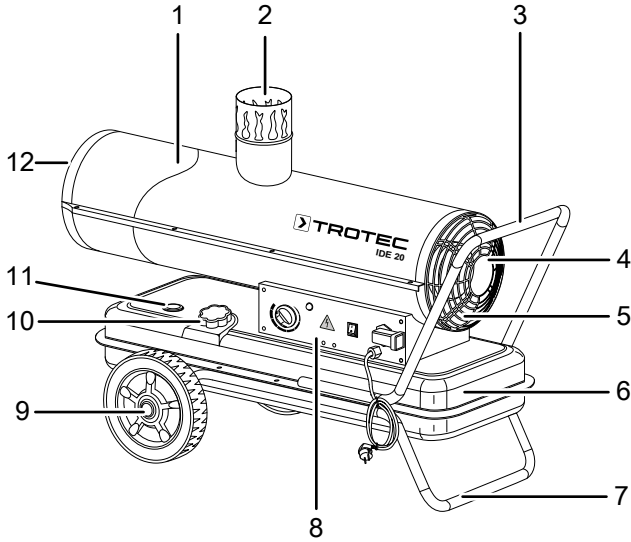

| No. | Designation                                    |
|-----|--|
| 1   | Combustion chamber housing                     |
| 2   | Flue pipe connection                           |
| 3   | Transport handle                               |
| 4   | Air inlet with protective grid                 |
| 5   | Fan and motor                                  |
| 6   | Tank   |
| 7   | Frame  |
| 8   | Control panel                                  |
| 9   | Wheel  |
| 10  | Fuel tank cap                                  |
| 11  | Tank filling level indication                  |
| 12  | Air outlet for hot air                         |
| 13  | External fuel filter (except for IDE 20)       |
| 14  | Danfoss injection pump (for IDE 20: fuel pump) |

## Transport and storage

### Note

If you store or transport the device improperly, the device may be damaged.

Note the information regarding transport and storage of the device.

### Transport

To make the device easier to transport, it is fitted with wheels.

To make the device easier to transport, it is fitted with a carry handle.

To make the device easier to transport, it is fitted with a transport handle and wheels.

**Before** transporting the device, observe the following:

- Switch the device off.
- Hold onto the mains plug while pulling the power cable out of the mains socket.
- Do not use the power cable to drag the device.
- Allow the device to cool down sufficiently.
- Before transporting or moving the device, make sure that the tank cap is tightly closed.

**While** transporting the device, observe the following:

- Slightly lift the device by the transport handle until the rear support no longer touches the ground.
- Wheel the device to the desired position.

### Storage

**Before** storing the device, proceed as follows:

- Hold onto the mains plug while pulling the power cable out of the mains socket.
- Allow the device to cool down sufficiently.

When the device is not being used, observe the following storage conditions:

- Store the device in a dry location and protected from frost and heat.
- Store the device in an upright position where it is protected from dust and direct sunlight.
- If required, use a cover to protect the device from invasive dust.

## Assembly and start-up

### Scope of delivery

- 1 x Oil heater
- 1 x Frame components
- 2 x Wheel
- 1 x Axle
- 1 x Carry handle
- 1 x Installation material
- 1 x Flue pipe connection
- 1 x Cable holder (IDE 30, IDE 50, IDE 60, IDE 80)
- 1 x Manual

### Unpacking the device

1. Open the cardboard box and take the device out.
2. Completely remove the packaging.
3. Fully unwind the power cable. Make sure that the power cable is not damaged and that you do not damage it during unwinding.

### Assembly

Upon delivery the devices are already partially preassembled.

The wheels, axle and frame still need to be mounted.

The assembly procedure is described below using the device IDE 20 as example.

#### Assembling the wheels

Prior to initial start-up, the wheels and the axle must be attached to the frame. To do so, please proceed as follows:

1. Slide the axle through the openings at the frame.

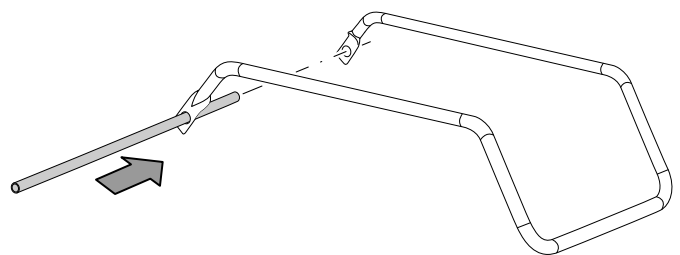

2. Attach both wheels to the axle.
3. Attach the locking rings to the axle.

4. Fasten the wheel caps to the wheels.

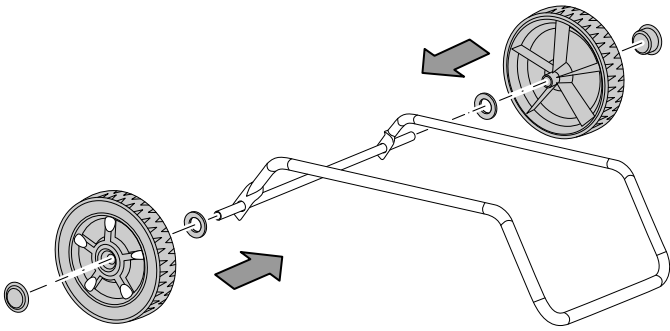

**Info**

If necessary, the frame can be disassembled again (e.g. for storage). To remove the wheels from the axle, you can carefully loosen the locking rings by means of a slotted screwdriver.

**Assembly of transport handle and frame**

1. Place the device on the frame. Make sure that the holes for the screws are positioned flush above each other.
2. First, bolt the 4 small screws to the frame.
3. Screw the nuts to the screws from below.
4. Place the transport handle on the rear of the device.
5. Bolt the 4 large screws to the transport handle, device and frame.

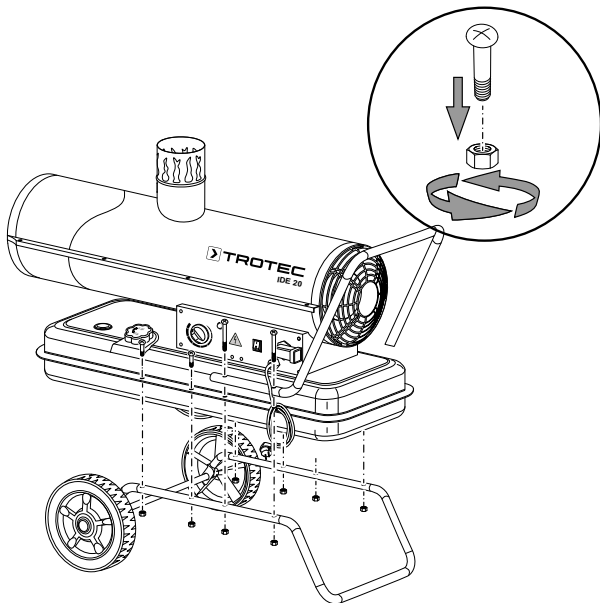

**Assembly of the cable holder (except for IDE 20)**

The devices are supplied with a cable holder (except for the IDE 20). Please proceed as follows to assemble the cable holder at the device:

1. Hold the cable holder to be mounted up against the side of the transport handle.
2. Make sure that the cable holder is attached at the pre-drilled holes.
3. Use the screws, washers and nuts to fasten the cable holder as illustrated below:

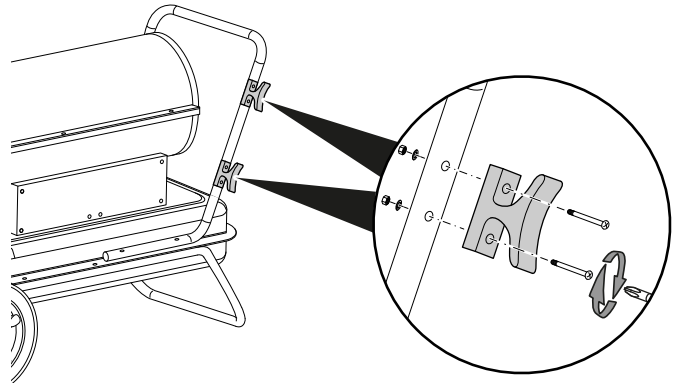

**Assembly of the exhaust line**



**Warning**

Note that this device must not be put into operation unless there is an exhaust line mounted at the flue pipe connection!

**Assembly of a closed exhaust line**



**Warning**

Make sure that in every operating and weather condition a vacuum of > 0.1 mbar is created in the exhaust line. This vacuum guarantees a safe discharge of exhaust gases from the room. The exhaust line must be installed upward. There must be no bends or elbows in the first 3 metres of the exhaust line!

If the device is used in closed rooms and the combustion gases are discharged via a chimney, a fresh air supply of approx. 80 m<sup>3</sup>/h (air inlet opening approx. 0.5 m<sup>2</sup>) must be ensured.

- Prior to planning the flue gas system, gather information about the national legislation and contact a responsible specialist (cf. DIN 18160 in Germany).
- Ensure an unimpeded and sufficient combustion air supply (e.g. by means of ventilation openings in doors, ceilings, windows, walls or via interconnected airways).
- Have the exhaust emission of the burner checked at regular intervals.

Below are some examples of good and bad exhaust gas discharge:

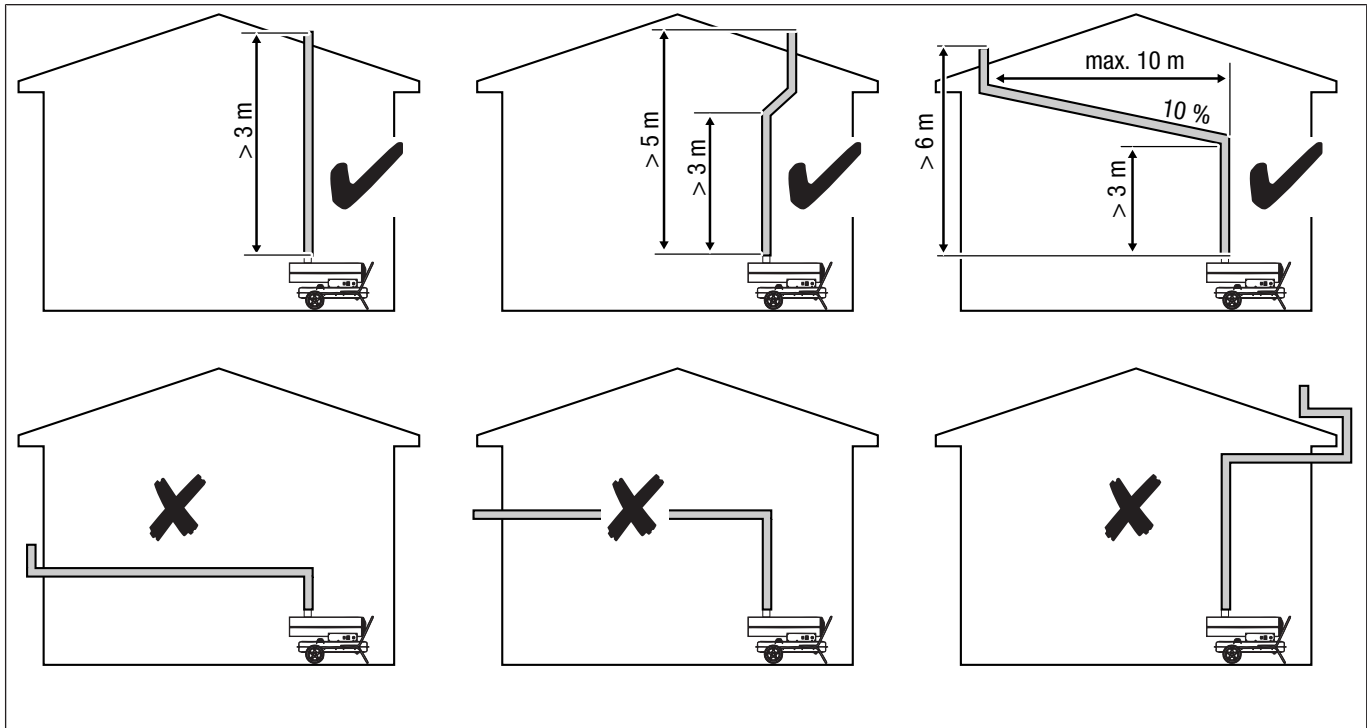

**Assembly of a flue pipe (optional)**

When the flue pipe is mounted to the flue pipe connection for the discharge of the exhaust gas, the device must only be operated in outdoor areas. Please observe the following:

- The flue pipe must not exceed a length of 1 m.
- Bends and elbows in the flue pipe are prohibited.
- If the device is used out of doors, a rain cap must be mounted to the end to prevent the penetration of rain water and dirt.
- The flue pipe must be designed in a way to prevent counter-pressure.
- To ensure failure-free operation the flue pipe must be installed upward.

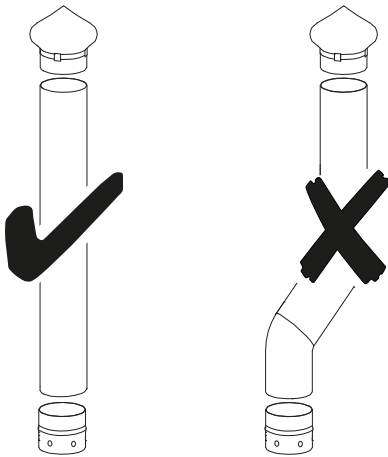

**Chimney duct**

The following schematic representation should be considered when planning a chimney duct:

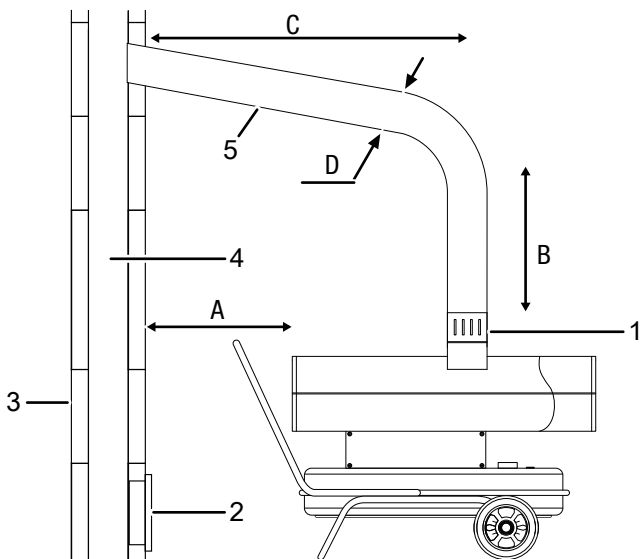

**Wall duct**

The following schematic representation should be considered when planning a wall duct:

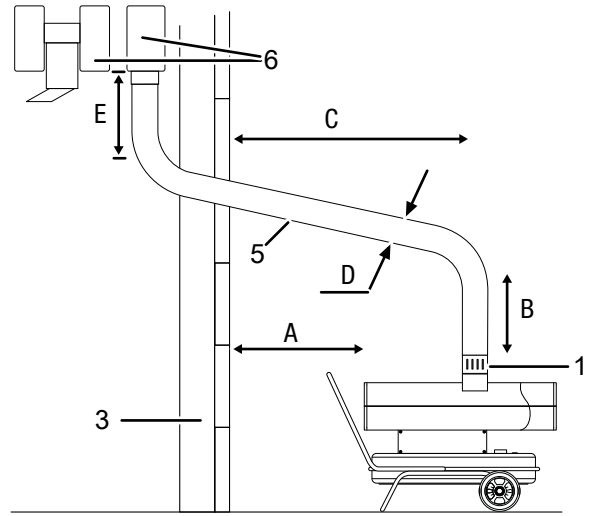

|   | Designation          |   | Designation                                     |
|---|----------------------|---|---|
| A | min. 2 m             | 1 | flue pipe connection                            |
| B | min. 3 m             | 2 | cleaning opening with explosion protection flap |
| C | as short as possible | 3 | outer wall                                      |
| D | ≥ Ø 120 mm / 150 mm  | 4 | chimney – inside min. 20 x 20 cm                |
| E | min. 1 m             | 5 | wall duct with elbow min. 5°                    |
|   |                      | 6 | draught booster H-shaped                        |

## Positioning

A number of spatial and technical conditions have to be considered for the selection of the device's installation site. Non-observance may impair the proper functioning of the device or the accessories or can entail risks of personal injury and property damage.

The following is to be observed for positioning:

- Do not operate the device for more than 3 months at the same place. Prior to planning the flue gas system, gather information about the national legislation and contact a responsible specialist.
- The device may only be operated on roofed over surfaces.
- The device is to be set up in a stable position on incombustible ground.
- The device must be set up in close proximity to a flue, an outer wall or on an open, ventilated surface.
- The device must be connected to a properly secured mains power socket.
- The room where the device is positioned must be sufficiently ventilated.

Ensure a sufficient fresh air supply, especially when there are people or animals in the same room with the device!

- The minimum distance between walls or other objects and the air outlet opening of the device must be at least 3 m (see figure).

The minimum distance between walls or other objects and the air inlet opening of the device must be at least 2 m (see figure).

There must be no walls or large objects near the device.

- The inlet and outlet openings must not be covered.
- There must be a sufficient number of fire extinguishers available.
- Avoid low or excess pressure in the installation space, since this could lead to combustion-related difficulties.

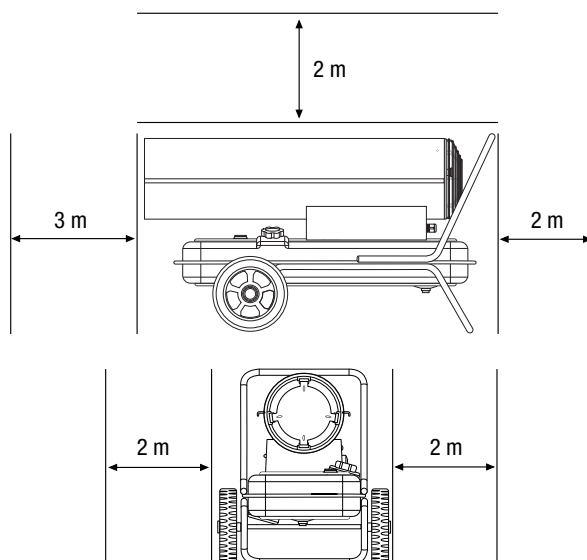

## Start-up

- Check the scope of delivery of your device for completeness. If an accessory part is missing, please contact the Trotec customer service or the specialist dealer where you purchased the device.
- Check the device and its connection parts for potential damage.
- Observe the conditions described in the chapter Positioning.
- Install the exhaust system of the device in a technically correct manner. You can also connect the device to a chimney or an outer wall as illustrated in chapter Assembly.
- Connect the device to an external tank or jerrycan as described in the Assembly chapter.
- Check the device for its proper condition prior to start-up and at regular intervals during application.
- Check whether the characteristics of the power grid conform to those on the nameplate.
- Each time before you plug the mains plug into the mains socket and switch on the device, make sure that the fan is moving freely.
- Connect the mains cable to a properly secured socket (230 V / 50 Hz / 10 A). On construction sites, there must be a residual current device (RCD) installed upstream of the socket in accordance with national regulations (in Germany: VDE 0100/0105).

The device is now ready for operation.

## Filling the tank



### Warning of flammable substances

In order to prevent fires, make sure that there are no ignition sources near the tank.

The fuel tank cap (10) and the tank filling level indication (11) of the IDE 20 are located at the side of the device next to the control panel. In case of the IDE 30, IDE 50, IDE 60 and IDE 80 the fuel tank cap (10) and the tank filling level indication (11) are located at the rear.

The figures in the description below show the IDE 20 by way of example.

- ✓ Before attempting to fill the tank, wait until the device has cooled down completely.
  - ✓ Only use fuel suitable for the device (see technical data).
1. Position the device on firm, level and incombustible ground.

2. Unscrew the fuel tank cap (10).

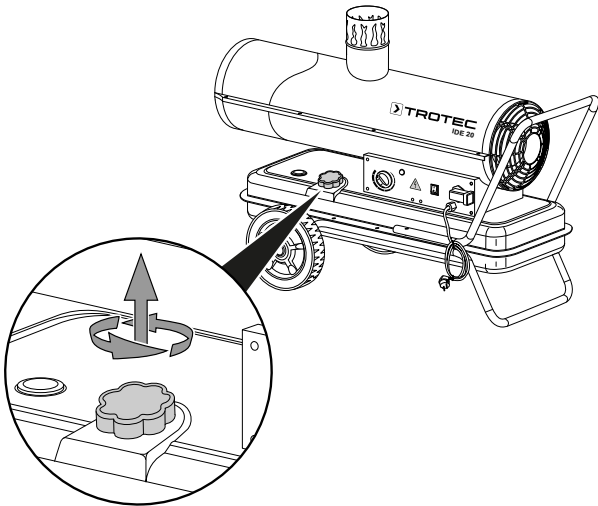

3. Fill the tank. In doing so, observe the filling level indication (11). Stop filling the tank just before the red range.
4. Screw the fuel tank cap (10) back onto the tank. Observe the recesses at the tank opening and the protrusions at the fuel tank cap. They must be aligned when attaching the fuel tank cap. Make sure that the fuel tank cap is firmly attached to avoid leakage.

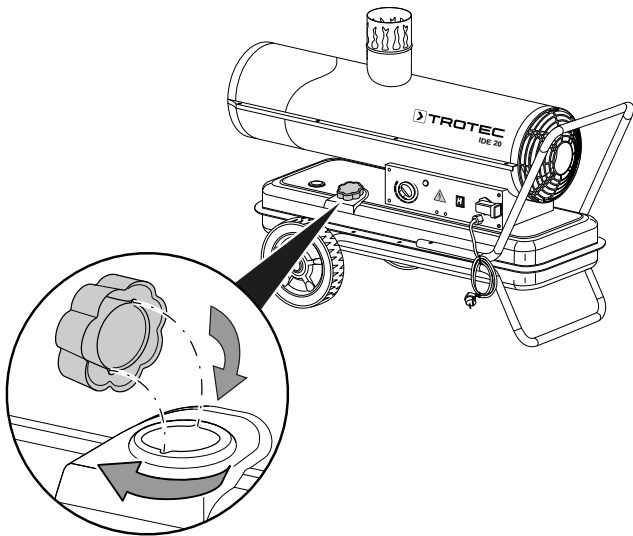

**Operation**

The device may only be used by accordingly instructed persons.

**Operating element**

IDE 20

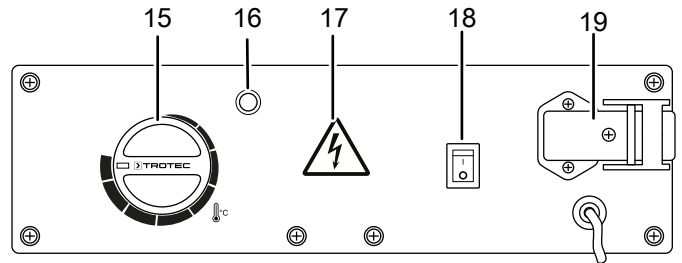

IDE 30 / IDE 50 / IDE 60 / IDE 80

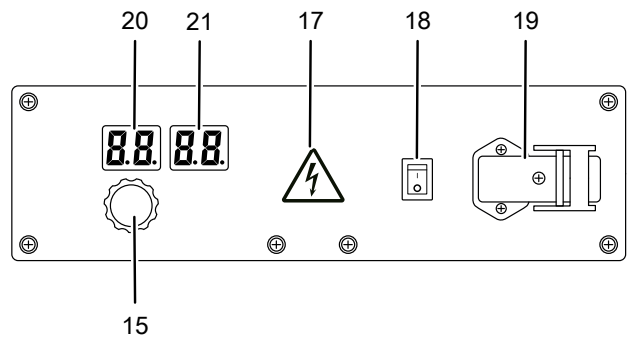

| No. | Designation                        |
|-----|------------------------------------|
| 15  | Rotary control thermostat          |
| 16  | Operating light                    |
| 17  | Warning sign                       |
| 18  | ON/OFF switch                      |
| 19  | Connection for external thermostat |
| 20  | Target value indication            |
| 21  | Room temperature indication        |

**Switching the device on**



**Wear hearing protection.**

Excessive noise can lead to hearing loss.

The device continues to operate until the desired room temperature is reached.

- Set the on/off switch (18) to position I.  
⇒ The on/off switch (18) is illuminated.
- Set the rotary control thermostat (15) to the desired room temperature. This value should be higher than the current room temperature. Use the figure below as reference.
- Ensure a successful ignition.

Switching the oil heater on (IDE 30 / IDE 50 / IDE 60 / IDE 80)

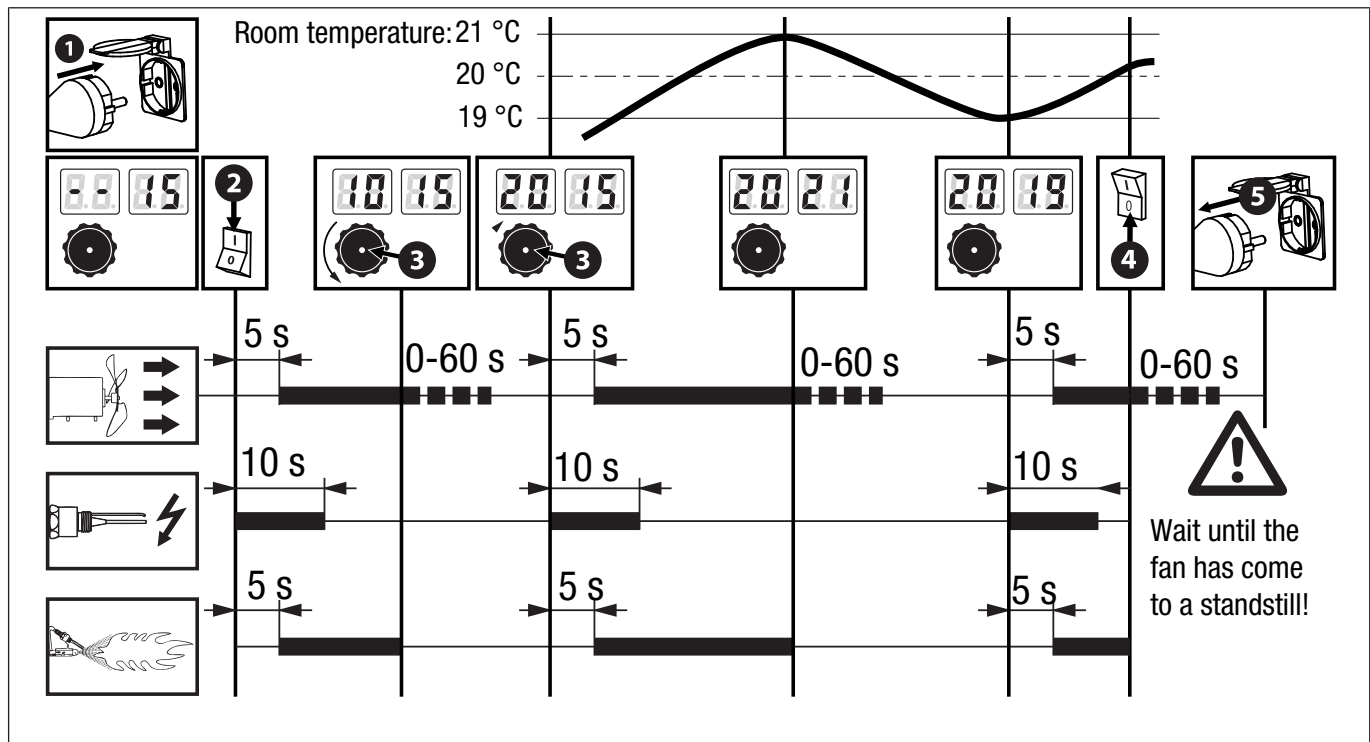

## Shutdown



### Warning of electrical voltage

Do not touch the mains plug with wet or damp hands.

### Note

Damage to the device due to overheating!

Never switch off the device by pulling the mains plug.

This may lead to overheating!

Switch off the device properly. Only remove the mains plug from the device once the fan motor has stopped completely.

## IDE 20

1. Turn the rotary control thermostat (15) to minimum.
2. If necessary, regulate the external thermostat to a low temperature using the settings of the controller.
3. Wait for approx. 90 s until the fan motor has come to a complete standstill.
4. Switch the device off by setting the on/off switch (18) to position **0**.  
⇒ The on/off switch (18) is no longer illuminated.
5. Secure the device against inadvertent switch-on by pulling the mains plug.
6. Allow the device to cool down completely.

## IDE 30 / IDE 50 / IDE 60 / IDE 80

1. Switch the device off by setting the on/off switch (18) to position **0**.  
⇒ The flame goes out and the fan continues to run for approx. 90 seconds in order to cool down the burner.
2. If you use a thermostat, switch off the device using the settings of the controller (e.g. by setting a lower temperature at the thermostat).
3. Wait for approx. 90 s until the fan motor has come to a complete standstill.
4. Secure the device against inadvertent switch-on by pulling the mains plug.
5. Allow the device to cool down completely.

## Restart after troubleshooting

During initial start-up and after the fuel oil circuit has been drained completely, the fuel oil supply to the nozzle may be insufficient. In this case, the flame monitoring system will respond and the device will be blocked. Proceed as follows:

1. Wait for approx. 1 minute.
2. Switch the device on.

If the device is still not starting, proceed as follows:

1. Make sure that there is fuel left in the tank.
2. Please refer to the chapters General safety warnings and Errors and faults.

## Available accessories

| Accessories                                   | IDE 20<br>Article number | IDE 30<br>Article number   | IDE 50<br>Article number   | IDE 60<br>Article number   | IDE 80<br>Article number   |
|---|--------------------------|----------------------------|----------------------------|----------------------------|----------------------------|
| Hose connector                                | -                        | Ø 300 mm<br>6.100.006.180  | Ø 440 mm<br>6.100.006.179  | Ø 440 mm<br>6.100.006.179  | Ø 440 mm<br>6.100.006.179  |
| External thermostat<br>with 25 m cable        | 6.100.006.113            | 6.100.006.112              | 6.100.006.112              | 6.100.006.112              | 6.100.006.112              |
| Exhaust gas pipe rigid,<br>length 1 m         | 6.100.006.212            | 6.100.006.212              | 6.100.006.210              | 6.100.006.210              | 6.100.006.210              |
| 90° arc connection for exhaust<br>gas pipe    | 6.100.006.218            | 6.100.006.218              | 6.100.006.216              | 6.100.006.216              | 6.100.006.216              |
| Exhaust gas pipe rain cover                   | 6.100.006.224            | 6.100.006.224              | 6.100.006.222              | 6.100.006.222              | 6.100.006.222              |
| Air hose Tronect SP-C <sup>1</sup>            | -                        | 6.100.001.265              | 6.100.001.270              | 6.100.001.270              | 6.100.001.270              |
| Connection kit for external oil<br>tank       | -                        | 6.100.006.183              | 6.100.006.183              | 6.100.006.183              | 6.100.006.183              |
| Adapter set tank kit – oil hose               | -                        | 7.210.000.003              | 7.210.000.003              | 7.210.000.003              | 7.210.000.003              |
| Tank line with quick couplings,<br>length 5 m | -                        | 6.100.006.037 <sup>2</sup> | 6.100.006.037 <sup>2</sup> | 6.100.006.037 <sup>2</sup> | 6.100.006.037 <sup>2</sup> |
| Fuel tank, 1,000 litres                       | -                        | 6.100.006.011              | 7.210.000.011              | 7.210.000.011              | 7.210.000.011              |
| Fuel tank, 3,000 litres                       | -                        | 6.100.006.012              | 6.100.006.012              | 6.100.006.012              | 6.100.006.012              |

<sup>1</sup> Important: The effective length of the hose for the above devices is limited to a maximum of 4 m! Tronect hoses with a standard effective length of 7.6 m will result in a forced switch-off and must be shortened by the user to a max. effective length of 4 m for the application.

<sup>2</sup> in combination with adapter set tank kit – oil hose (required accessories)



### Warning

Only use accessories and additional equipment specified in the instructions.

Using insertion tools or accessories other than those specified in the instructions may cause a risk of injury.

## Errors and faults



### Warning of electrical voltage

**Tasks which require the device to be opened must only be carried out by authorised specialist companies or by Trotec.**



### Warning

Risk of injury due to improper repair!

Never try to make any modifications or repairs on the device.

Unauthorised modifications can lead to serious injuries or death.

Have a certified specialist workshop perform the repair work.

### Note

Wait for at least 3 minutes after maintenance and repair work. Only then switch the device back on.

The device has been checked for proper functioning several times during production. If malfunctions occur nonetheless, check the device according to the following list.

### The device does not start:

- Check the power connection.
- Check the on-site fusing.

### Smoke and/or sparks are emitted during first use:

- This is not a fault. These phenomena disappear after a brief runtime.

### Noise emission during ignition or cooling:

- This is not a fault. The metal parts of the device expand when heated and generate noise.

### Sparks and/or flames are issued from the device's front or rear during ignition:

- This is not a fault. Air might have accumulated in the lines. Keep a safety distance to the openings of the device!

### The flame in the combustion chamber does not ignite:

- Check the filling level of the tank. Refill fuel if the tank is empty (see Filling the tank).
- Check the fuel filter and the fuel pump for dirt. If it is dirty, please contact the customer service.
- Check the fuel for contaminations, e.g. dirt or water. If required, drain the fuel completely and fill in new and clean fuel (see Filling the tank).
- Safety shutdown: if the flame dies during operation, the electronics and the oil pump will be switched off. Investigate the cause on the basis of the following criteria:

- **For qualified personnel only!**

Check the ignition: The distance between the two ignition electrodes should be 4 to 5 mm.

### The flame goes out during combustion:

- Make sure the air supply is unobstructed. If required, clean the air intake opening.
- Check the filling level of the tank. Refill fuel if the tank is empty (see Filling the tank).
- Check the fuel filter and the fuel pump for dirt. If it is dirty, please contact the customer service.
- Check the fuel for contaminations, e.g. dirt or water. If required, drain the fuel completely and fill in new and clean fuel (see Filling the tank).
- Power failure: In the event of a power failure the ignition is extinguished, the device switches off immediately. After a power failure the device will not restart automatically, it has to be started via the on/off switch.

### There is a fuel leak:

- Check whether too much fuel was filled in. Drain the fuel if necessary, see chapter Draining the tank.
- Check the drain screw for tight fit and retighten it if necessary.
- Check the sealing at the drain screw and replace it if damaged.
- Check the fuel pump for leaks. If there are doubts about the proper condition of the fuel pump, please contact the customer service.

### The device emits smoke or dust:

- Check the fuel for contaminations, e.g. dirt or water. If required, drain the fuel completely and fill in new and clean fuel (see Filling the tank).

### The flame emerges from the air outlet:

- Check the fuel for contaminations and replace it if required.
- Check the tank for contaminations and drain it if required (see chapter Maintenance). Refill with clean fuel.

### The device still does not operate correctly after these checks:

Please contact the customer service. If necessary, bring the device to an authorised specialist electrical company or to Trotec for repair.

## Error codes

The following errors may occur:

| IDE 20  |   |   |
|---|---|---|
| Fault/error code  | Cause   | Remedy  |
| The motor does not start and the operating display flashes.                       | There is no power supply/supply voltage or it is too low.         | Check the power line/voltage supply.<br>Check the fusing and have it replaced if necessary.   |
|   | The power cable is damaged or defective.                          | Check the power cable and have it replaced if necessary.  |
|   | The motor or the capacitor is/are defective.                      | Check the motor and capacitor and have the motor and/or capacitor replaced if necessary.  |
|   | The device switches off due to overheating.                       | Investigate the cause of overheating.<br>Switch the device off.<br>Check whether the air inlet and air outlet are blocked or obstructed and rectify the fault. Wait for a few minutes and restart the device. |
| The motor is running but the heater does not ignite and locks after a short time. | The device contains contaminated or incorrect fuel.               | Empty the fuel tank. Fill the tank with clean diesel or kerosene (see chapter Maintenance).   |
|   | The fuel filter is clogged.                                       | Replace or clean the fuel filter.   |
| The operating display flashes.  | There is air in the oil line.                                     | Check the hoses and tighten the connections. Replace damaged oil lines.   |
|   | The burner nozzle is clogged.                                     | Clean the burner nozzle by means of compressed air. Replace burner nozzles that cannot be cleaned or that are damaged.  |
|   | Fuel viscosity has increased due to low temperatures.             | Mix the fuel diesel with 10-20 % kerosene.  |
| Flames come out of the flue pipe outlet.  | The air flow in the combustion chamber is too low.                | Contact a specialist company. Have the positions of the air inlet, fan, motor and air sleeve checked and adjusted if necessary  |
|   | The fuel pressure is set incorrectly.                             | Contact a specialist company. Have the fuel pressure checked and adjusted if necessary.   |
| The device stops during operation:  | The room temperature set on the room thermostat has been reached. | Turn the temperature controller clockwise to a higher setting to switch the device back on.   |
| The device stops during operation and the operating display lights up.            | No flame can be produced.   | Set the on/off switch to position 0 and then to position I. If the malfunctions persist, contact the customer service.  |
|   | Poor combustion.  |   |
|   | The air current is reduced.                                       |   |
|   | The device is overheating.  |   |

| <b>IDE 30, IDE 50, IDE 60, IDE 80</b>   |  |  |
|---|--|--|
| <b>Fault/error code</b>   | <b>Cause</b>   | <b>Remedy</b>  |
| The motor does not start. The error code E1 appears on the display.   | There is no power supply/supply voltage or it is too low.  | Check the power line/voltage supply.<br>Check the fusing and have it replaced if necessary.  |
|   | The power cable is damaged or defective.   | Check the power cable and have it replaced if necessary.   |
|   | The motor or the capacitor is/are defective.   | Check the motor and capacitor and have the motor and/or capacitor replaced if necessary.   |
|   | The device switches off due to overheating.  | Investigate the cause of overheating. Switch the device off.<br>Check whether the air inlet and air outlet are blocked or obstructed and rectify the fault. Wait for a few minutes and restart the device. |
| The error code E2 appears on the display.   | The temperature sensor is defective or the connection for the temperature sensor has come loose. | Check and replace the temperature sensor if necessary.   |
|   |  | Check and replace the printed circuit board if necessary.  |
| The motor is running but the heater does not ignite and locks after a short time. The error code E1 appears on the display. | The device contains contaminated or incorrect fuel.  | Empty the fuel tank. Fill the tank with clean diesel or kerosene (see chapter Maintenance).  |
|   | The fuel filter is clogged.  | Replace or clean the fuel filter.  |
|   | There is an ignition fault. The electrodes are dirty or incorrectly positioned.                  | Check the electrodes and adjust them if necessary.   |
|   | The burner nozzle is clogged.  | Clean the burner nozzle by means of compressed air. Replace burner nozzles that cannot be cleaned or that are damaged.   |
|   | Fuel viscosity has increased due to low temperatures.  | Mix the fuel diesel with 10-20 % kerosene.   |
| The heating process starts but the combustion quality is not good.  | The air flow in the combustion chamber is too low.   | Check the positions of the air inlet, fan, motor and air sleeve and adjust the positions if necessary.   |
|   | The fuel pressure is set incorrectly.  | Check the fuel pressure and adjust it if necessary.  |
|   | Leaky fuel line.   | Check for possible fuel leaks and rectify them.  |
| The heating device stops during operation: The ambient temperature is indicated on the display.                             | The room temperature set on the room thermostat has been reached.                                | Turn the temperature controller clockwise to a higher setting to switch the device back on.  |
| The heating process does not start. The error code LC appears on the display.   | If ignition has failed three times, the circuit board has been locked and operation is stopped.  | Switch on the power and press the on/off switch for three times, then it will unlock after 10 seconds.   |
| The device stops during operation: The error code E1 appears on the display.  | No flame can be produced.  | Set the on/off switch to position 0 and then to position I. If the malfunctions persist, contact the customer service.   |
|   | Poor combustion.   |  |
|   | The air current is reduced.  |  |
|   | The device is overheating.   |  |

## Maintenance

## Maintenance intervals

| Maintenance and care interval  | before every start-up | as needed | at least every 2 weeks | at least every 4 weeks | at least every 6 months | at least annually |
|--|-----------------------|-----------|------------------------|------------------------|-------------------------|-------------------|
| Check air inlets and outlets for dirt and foreign objects and clean if necessary | X                     |           |                        |                        |                         |                   |
| Check air inlet grid(s) for dirt and foreign objects and clean if necessary      | X                     |           | X                      |                        |                         |                   |
| Clean the exterior   |                       | X         |                        |                        |                         | X                 |
| Visually check the inside of the device for dirt                                 |                       | X         |                        | X                      |                         |                   |
| Check for damage   | X                     |           |                        |                        |                         |                   |
| Check the attachment screws  |                       | X         |                        |                        |                         | X                 |
| Test run   |                       |           |                        |                        |                         | X                 |

## Maintenance and care log

Device type: .....

Device number: .....

| Maintenance and care interval  | 1 | 2 | 3 | 4 | 5 | 6 | 7 | 8 | 9 | 10 | 11 | 12 | 13 | 14 | 15 | 16 |
|--|---|---|---|---|---|---|---|---|---|----|----|----|----|----|----|----|
| Check air inlets and outlets for dirt and foreign objects and clean if necessary |   |   |   |   |   |   |   |   |   |    |    |    |    |    |    |    |
| Check air inlet grid(s) for dirt and foreign objects and clean if necessary      |   |   |   |   |   |   |   |   |   |    |    |    |    |    |    |    |
| Clean the exterior   |   |   |   |   |   |   |   |   |   |    |    |    |    |    |    |    |
| Visually check the inside of the device for dirt                                 |   |   |   |   |   |   |   |   |   |    |    |    |    |    |    |    |
| Check for damage   |   |   |   |   |   |   |   |   |   |    |    |    |    |    |    |    |
| Check the attachment screws  |   |   |   |   |   |   |   |   |   |    |    |    |    |    |    |    |
| Test run   |   |   |   |   |   |   |   |   |   |    |    |    |    |    |    |    |
| Comments   |   |   |   |   |   |   |   |   |   |    |    |    |    |    |    |    |

|                  |                  |                  |                  |
|------------------|------------------|------------------|------------------|
| 1. Date: .....   | 2. Date: .....   | 3. Date: .....   | 4. Date: .....   |
| Signature: ..... | Signature: ..... | Signature: ..... | Signature: ..... |
| 5. Date: .....   | 6. Date: .....   | 7. Date: .....   | 8. Date: .....   |
| Signature: ..... | Signature: ..... | Signature: ..... | Signature: ..... |
| 9. Date: .....   | 10. Date: .....  | 11. Date: .....  | 12. Date: .....  |
| Signature: ..... | Signature: ..... | Signature: ..... | Signature: ..... |
| 13. Date: .....  | 14. Date: .....  | 15. Date: .....  | 16. Date: .....  |
| Signature: ..... | Signature: ..... | Signature: ..... | Signature: ..... |

**Activities required before starting maintenance**



**Warning of electrical voltage**

Do not touch the mains plug with wet or damp hands.

- Switch the device off.
- Hold onto the mains plug while pulling the power cable out of the mains socket.
- Allow the device to cool down completely.



**Warning of electrical voltage**

**Tasks which require the device to be opened must only be carried out by authorised specialist companies or by Trotec.**

**Cleaning the housing**

Clean the housing with a soft, damp and lint-free cloth. Make sure that no moisture enters the housing. Protect electrical components from moisture. Do not use any aggressive cleaning agents such as cleaning sprays, solvents, alcohol-based or abrasive cleaners to dampen the cloth.

Wipe the housing dry after cleaning.

For a smooth operation of the device, the combustion chamber, the burner and the fan must be cleaned regularly.

Have the combustion chamber cleaned by the customer service.

**Cleaning after every 50 operating hours**

1. Remove the fuel oil filter. Take out the filter insert and clean it with clean fuel oil.
2. Dismantle the upper part of the housing and clean the inner section and the fan blades with a cleaning fleece and, in case of heavy soiling, with a brass brush.
3. Check the condition off all cables and of the high-voltage plugs.
4. Dismantle the burner and clean its components with a brass brush.
5. Clean the electrodes. Check the distance of the electrodes and adjust if necessary (see figure).

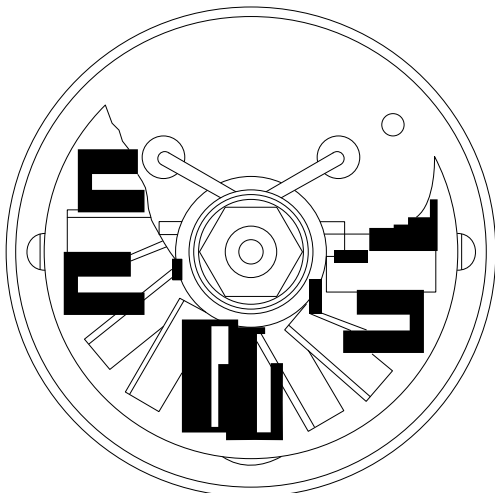

**Draining the tank**



**Warning of flammable substances**

In order to prevent fires, make sure that there are no ignition sources near the tank.

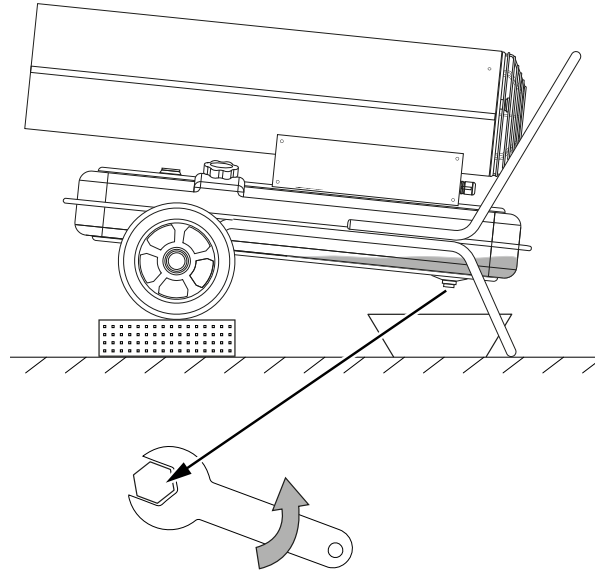

1. Provide for a suitable collection container.
2. Move the device to an elevated position.
3. As indicated in the figure use a wrench to open the screw at the bottom of the tank.
4. Drain the fuel into the collection container.
5. When no more fuel is discharged, seal the drain hole again.
  - ⇒ Ensure the tight fit of the screw and, if required, replace the seal, for otherwise fuel might leak out uncontrollably.
6. Dispose of the fuel according to national regulations.

6. Assemble the components in reverse order.

**Technical annex**
**Technical data**

| Parameter                                  | Value                           |                                 |                                 |                                 |                                 |
|--|---------------------------------|---------------------------------|---------------------------------|---------------------------------|---------------------------------|
| Model                                      | IDE 20                          | IDE 30                          | IDE 50                          | IDE 60                          | IDE 80                          |
| Combustion                                 | indirect                        | indirect                        | indirect                        | indirect                        | indirect                        |
| Air flow rate                              | 600 m <sup>3</sup> /h           | 780 m <sup>3</sup> /h           | 2000 m <sup>3</sup> /h          | 2000 m <sup>3</sup> /h          | 2000 m <sup>3</sup> /h          |
| Fan  | axial fan                       | axial fan                       | axial fan                       | axial fan                       | axial fan                       |
| Nominal heat output                        | 20 kW                           | 30 kW                           | 50 kW                           | 60 kW                           | 80 kW                           |
| Power consumption                          | 230 W                           | 250 W                           | 900 W                           | 900 W                           | 900 W                           |
| Operating temperature                      | -20 °C to +45 °C                | -20 °C to +45 °C                | -20 °C to +45 °C                | -20 °C to +45 °C                | -20 °C to +45 °C                |
| Relative humidity during operation         | max. 80 % RH                    | max. 80 % RH                    | max. 80 % RH                    | max. 80 % RH                    | max. 80 % RH                    |
| Temperature increase ΔT                    | 90 °C                           | 95 °C                           | 95 °C                           | 90 °C                           | 105 °C                          |
| Max. fuel consumption                      | 1.9 l/h                         | 2.8 l/h                         | 4.8 l/h                         | 5.7 l/h                         | 7.6 l/h                         |
| Tank capacity                              | 24 l                            | 50 l                            | 69 l                            | 69 l                            | 69 l                            |
| Flue pipe connection Ø                     | 120                             | 120                             | 150                             | 150                             | 150                             |
| Input voltage                              | 230 V / 50 Hz                   | 230 V / 50 Hz                   | 230 V / 50 Hz                   | 230 V / 50 Hz                   | 230 V / 50 Hz                   |
| Current consumption                        | 1.1 A                           | 1.5 A                           | 3.2 A                           | 3.2 A                           | 3.3 A                           |
| Overheating protection                     | yes                             | yes                             | yes                             | yes                             | yes                             |
| Connection for external thermostat         | yes                             | yes                             | yes                             | yes                             | yes                             |
| Sound pressure level (distance 1 m)        | 79 dB(A)                        | 78 dB(A)                        | 79 dB(A)                        | 79 dB(A)                        | 80 dB(A)                        |
| Type of protection                         | IPX4                            | IPX4                            | IPX4                            | -                               | -                               |
| Weight (with empty tank)                   | 22.5 kg                         | 34.5 kg                         | 60.5 kg                         | 60 kg                           | 59 kg                           |
| Dimensions (length x width x height)       | 900 x 450 x 645 mm              | 1107 x 498 x 766 mm             | 1365 x 600 x 985 mm             | 1370 x 560 x 995 mm             | 1370 x 560 x 995 mm             |
| Minimum distance to walls or other objects |                                 |                                 |                                 |                                 |                                 |
| top  | 2 m                             | 2 m                             | 2 m                             | 2 m                             | 2 m                             |
| rear                                       | 2 m                             | 2 m                             | 2 m                             | 2 m                             | 2 m                             |
| sides                                      | 3 m                             | 3 m                             | 3 m                             | 3 m                             | 3 m                             |
| front                                      | 3 m                             | 3 m                             | 3 m                             | 3 m                             | 3 m                             |
| Permitted fuel                             | EL fuel oil, diesel or kerosene | EL fuel oil, diesel or kerosene | EL fuel oil, diesel or kerosene | EL fuel oil, diesel or kerosene | EL fuel oil, diesel or kerosene |



**Wear hearing protection.**

Excessive noise can lead to hearing loss.

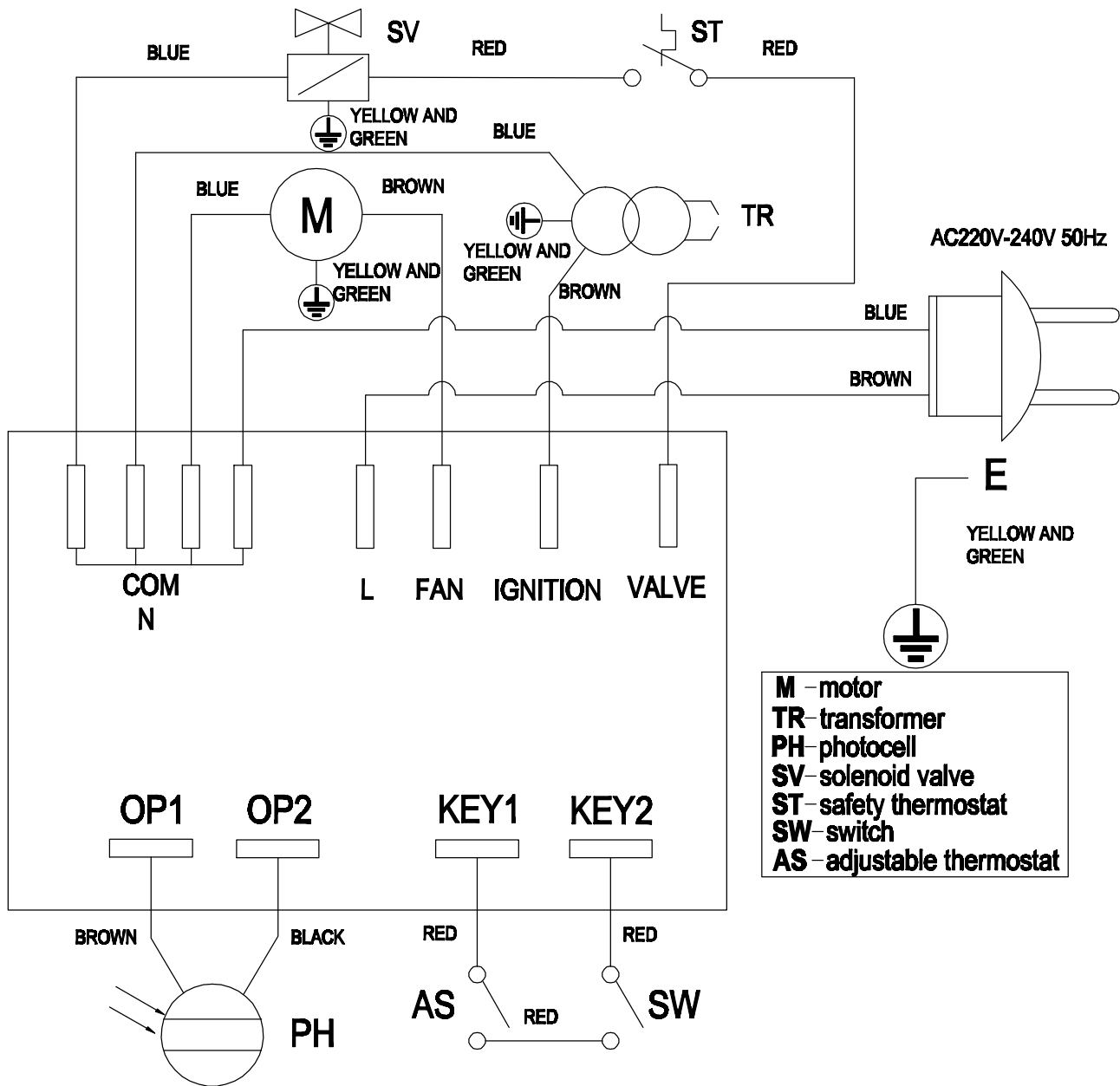
Wiring diagram IDE 20

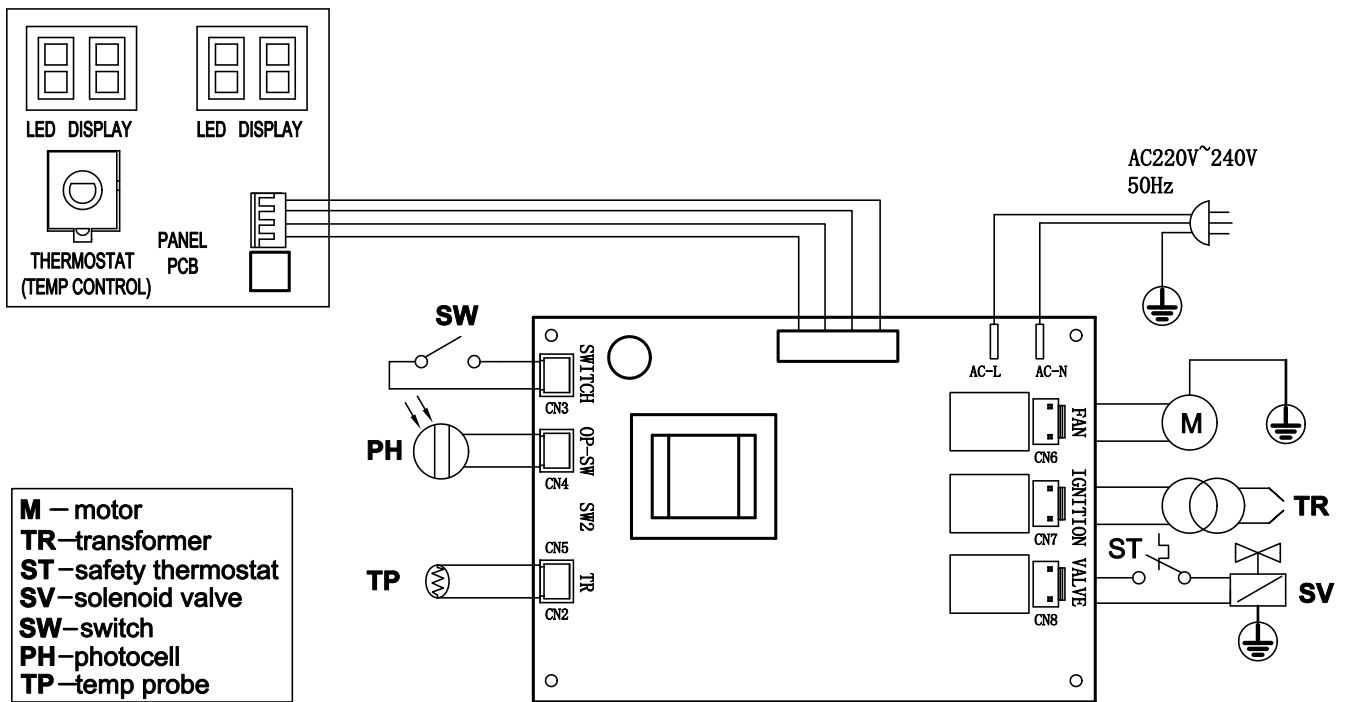

Wiring diagram IDE 30 / IDE 50 / IDE 60 / IDE 80



**Overview of spare parts IDE 20**

**Note!**

The position numbers of the spare parts differ from those describing the positions of the components mentioned in these instructions.

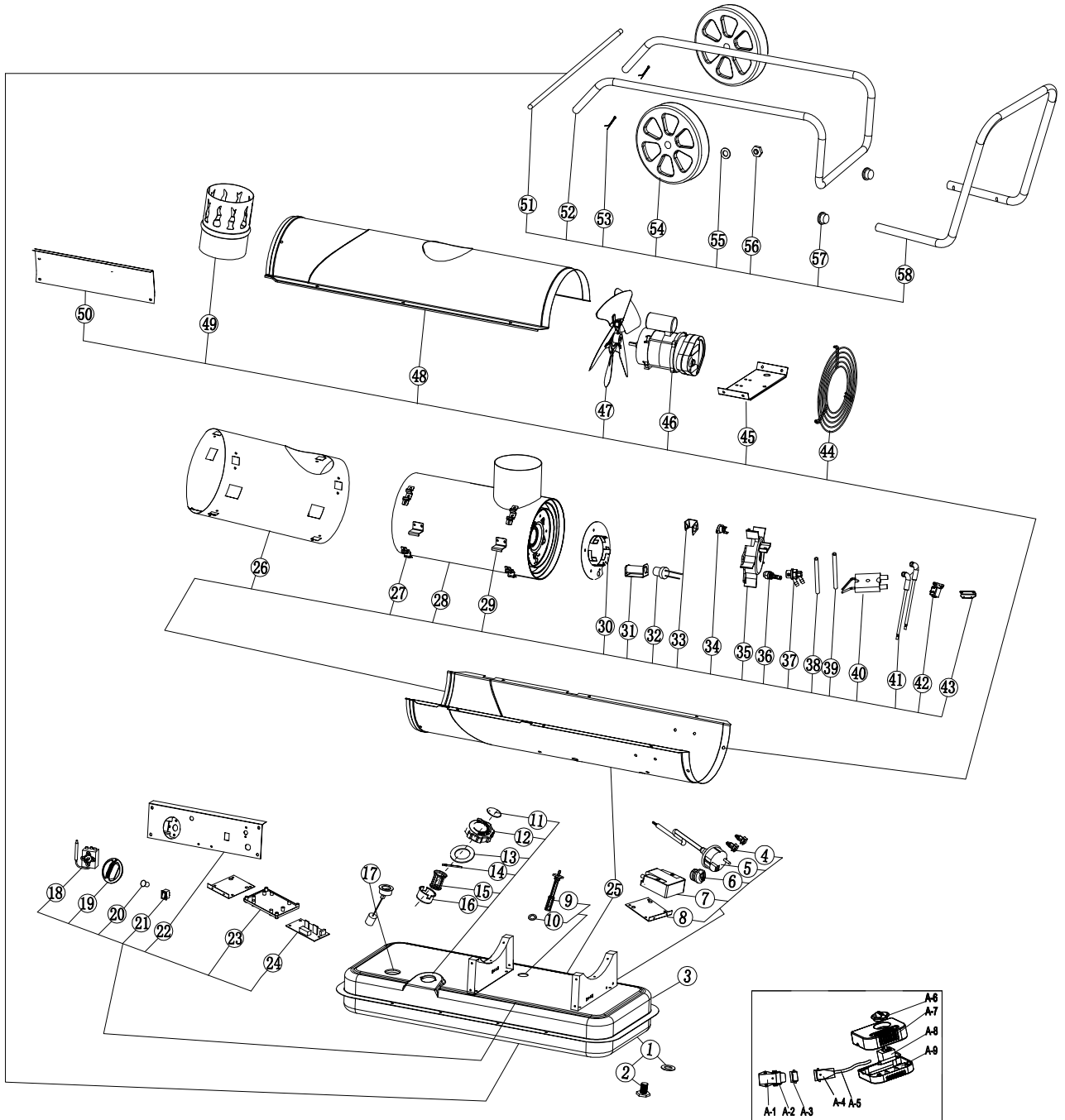

### Spare parts list IDE 20

| NO. | SPARE PART                      | NO. | SPARE PART                 | NO. | SPARE PART           |
|-----|---------------------------------|-----|----------------------------|-----|----------------------|
| 1   | Oil drain seal Ring             | 24  | Power PCB                  | 47  | Fan                  |
| 2   | Oil drain screw                 | 25  | Bottom casing              | 48  | Top cover            |
| 3   | Fuel tank                       | 26  | Heat insulation casing     | 49  | Chimney connector    |
| 4   | Support                         | 27  | Chamber bracket            | 50  | Side plate           |
| 5   | Power cord                      | 28  | Combustion chamber         | 51  | Wheel axle           |
| 6   | Cable fastener                  | 29  | Hook                       | 52  | Feet pipe            |
| 7   | Ignition transformer            | 30  | Air inlet disc             | 53  | Cotter pin           |
| 8   | Bracket Of Ignition transformer | 31  | Photocell assembly bracket | 54  | Wheel                |
| 9   | Fuel filter                     | 32  | Photocell assembly         | 55  | Flat gasket          |
| 10  | Sealing ring                    | 33  | Re-set thermostat bracket  | 56  | Screw nut            |
| 11  | Breath cover                    | 34  | Re-set thermostat          | 57  | Steel pipe plug      |
| 12  | Fuel tank cap                   | 35  | Flame plate                | 58  | Handle               |
| 13  | Sealing ring                    | 36  | Nozzle assembly            | A-1 | Socket               |
| 14  | Tank cap shaft                  | 37  | Nozzle Adapter             | A-2 | Buckle               |
| 15  | Oil inlet filter holder         | 38  | Gas hose                   | A-3 | Socket cap           |
| 16  | Oil inlet filter                | 39  | Oil hose                   | A-4 | Plug                 |
| 17  | Oil leveler                     | 40  | Ignition needle            | A-5 | Line                 |
| 18  | Capillary thermostat            | 41  | High voltage cable         | A-6 | Knob                 |
| 19  | Thermostat knob                 | 42  | Solenoid valve             | A-7 | Top cover            |
| 20  | Light cover                     | 43  | Solenoid valve bracket     | A-8 | Capillary thermostat |
| 21  | On/off Switch                   | 44  | Air inlet grill            | A-9 | Bottom cover         |
| 22  | Control panel                   | 45  | Motor support              |     |                      |
| 23  | PCB bracket                     | 46  | Motor assembly             |     |                      |

**Overview of spare parts IDE 30**

**Note!**

The position numbers of the spare parts differ from those describing the positions of the components mentioned in these instructions.

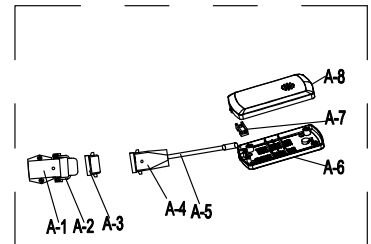
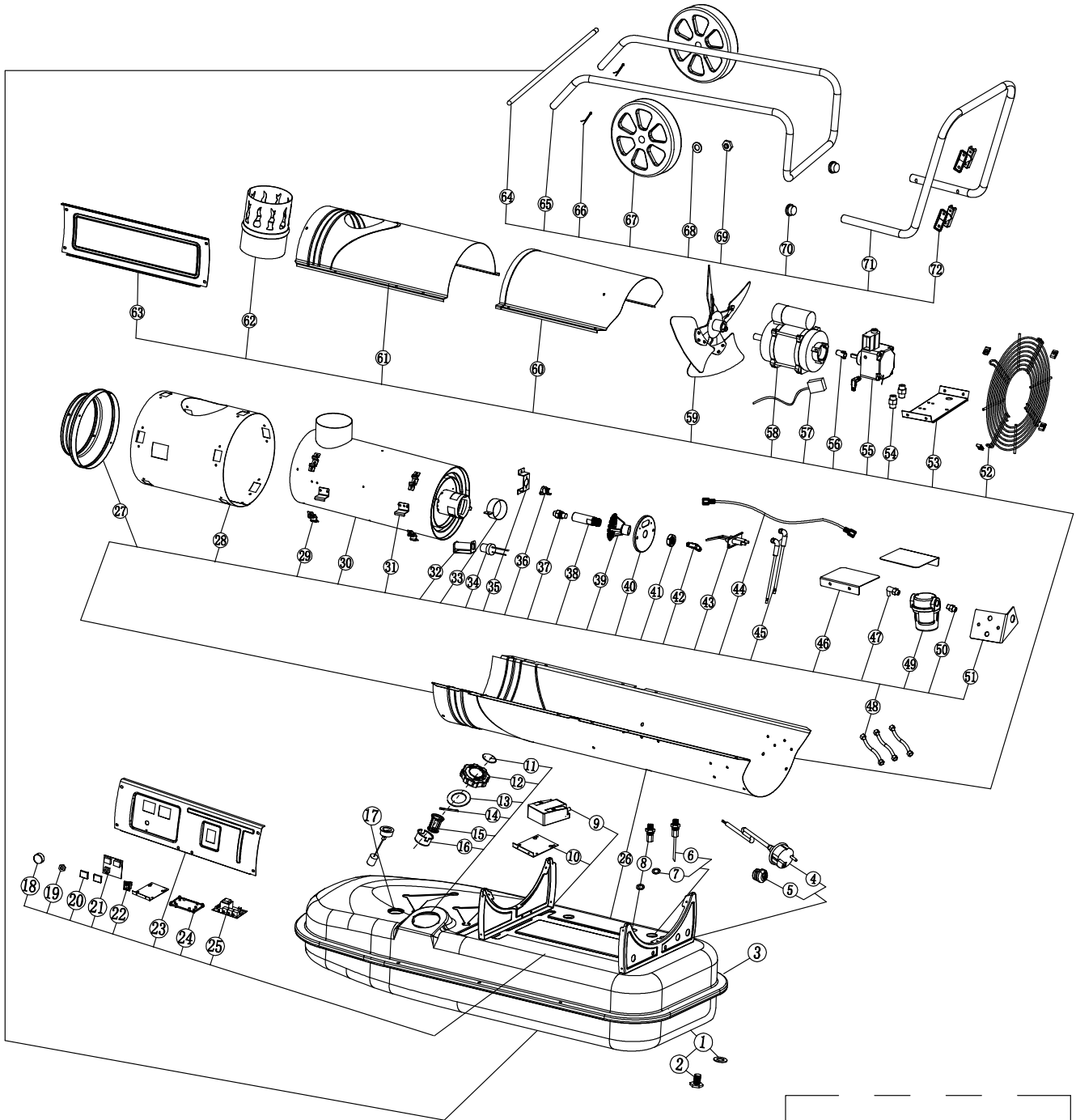

### Spare parts list IDE 30

| NO. | SPARE PART                      | NO. | SPARE PART                 | NO. | SPARE PART            |
|-----|---------------------------------|-----|----------------------------|-----|-----------------------|
| 1   | Oil drain seal ring             | 28  | Heat insulation casing     | 55  | Gear pump             |
| 2   | Oil drain screw                 | 29  | Chamber bracket            | 56  | Gear pump axle sleeve |
| 3   | Fuel tank                       | 30  | Combustion chamber         | 57  | Solenoid valve cord   |
| 4   | Power cord                      | 31  | Hook                       | 58  | Motor                 |
| 5   | Cable fastener                  | 32  | Photocell assembly bracket | 59  | Fan                   |
| 6   | Oil suction pipe                | 33  | Air adjustment ring        | 60  | Top bracket cover     |
| 7   | Sealing ring                    | 34  | Photocell assembly         | 61  | Top front cover       |
| 8   | Oil return pipe                 | 35  | Re-set thermostat bracket  | 62  | Chimney connector     |
| 9   | Ignition transformer            | 36  | Re-set thermostat          | 63  | Side plate            |
| 10  | Bracket of Ignition transformer | 37  | Nozzle assembly            | 64  | wheel axle            |
| 11  | Breath cover                    | 38  | Nozzle Adapter             | 65  | Feet pipe             |
| 12  | Fuel tank cap                   | 39  | Swirl disc                 | 66  | Cotter pin            |
| 13  | Sealing ring                    | 40  | Nozzle base plate          | 67  | Wheel                 |
| 14  | Tank cap shaft                  | 41  | Screw nut                  | 68  | Flat gasket           |
| 15  | Oil inlet filter holder         | 42  | Copper bend connector      | 69  | Screw nut             |
| 16  | Oil inlet filter                | 43  | Ignition needle            | 70  | Steel pipe plug       |
| 17  | Oil leveler                     | 44  | Oil tube assembly          | 71  | Handle                |
| 18  | Thermostat knob                 | 45  | High voltage cable         | 72  | Cable holder          |
| 19  | Thermo cut-off adjust nut       | 46  | Wind shield                | A-1 | Socket                |
| 20  | Display window                  | 47  | Nozzle bend connector      | A-2 | Buckle                |
| 21  | Display PCB2                    | 48  | Oil pipe                   | A-3 | Socket cap            |
| 22  | On/off switch                   | 49  | Filter                     | A-4 | Plug                  |
| 23  | Control panel                   | 50  | Filter connector           | A-5 | Remote control cable  |
| 24  | PCB support                     | 51  | Filter support             | A-6 | Bottom cover          |
| 25  | Power PCB1                      | 52  | Air inlet grill            | A-7 | Fixing clip           |
| 26  | Bottom casing                   | 53  | Motor support              | A-8 | Top cover             |
| 27  | Air outlet                      | 54  | Fuel filter joint          |     |                       |

**Overview of spare parts IDE 50 / IDE 60 / IDE 80**

**Note!**

The position numbers of the spare parts differ from those describing the positions of the components mentioned in these instructions.

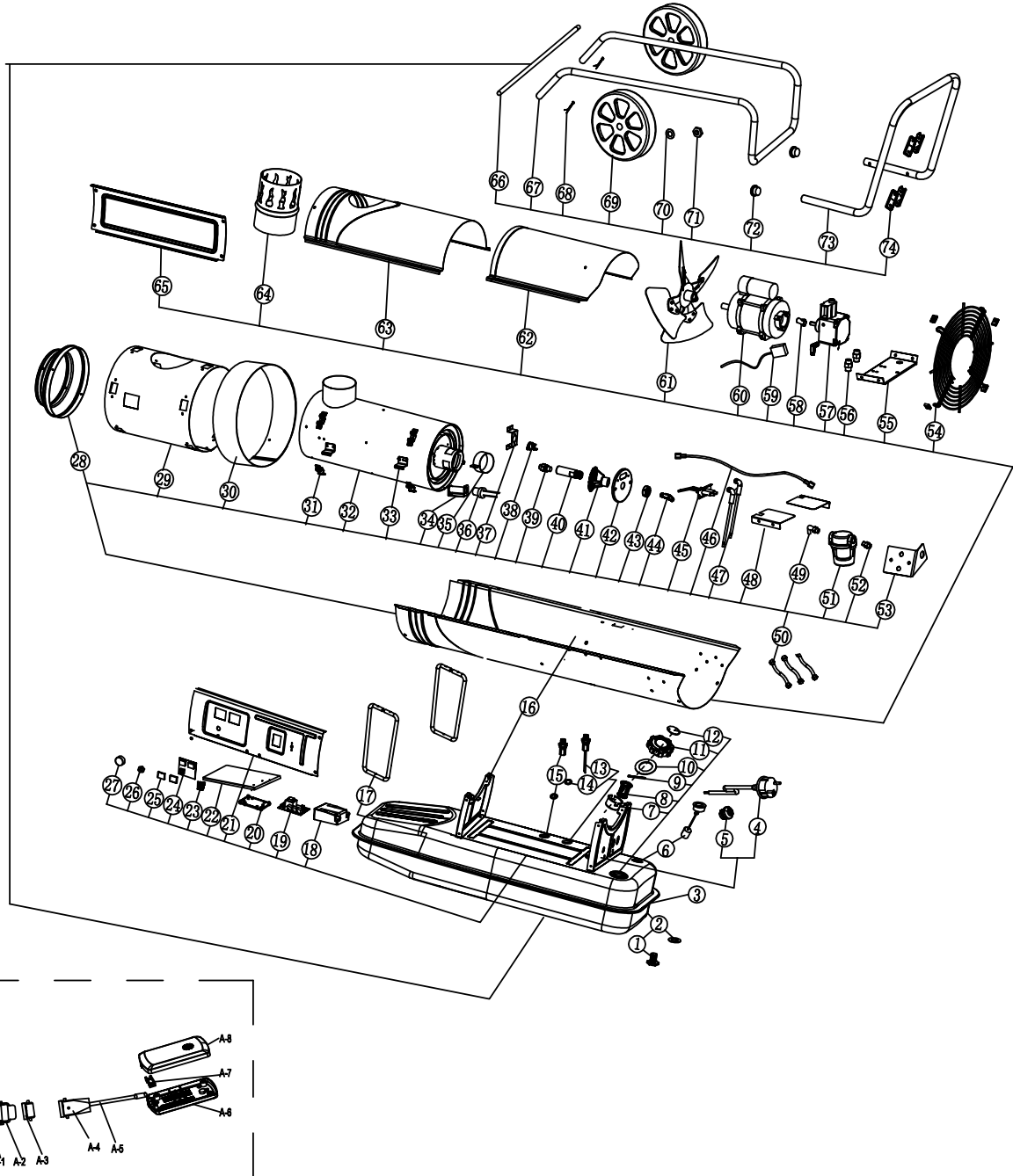

## Overview of spare parts IDE 50 / IDE 60 / IDE 80

| NO. | SPARE PART              | NO. | SPARE PART                 | NO. | SPARE PART        |
|-----|-------------------------|-----|----------------------------|-----|-------------------|
| 1   | Oil drain screw         | 29  | Heat insulation casing     | 57  | Gear pump         |
| 2   | Oil drain seal ring     | 30  | Casing support ring        | 58  | Pump coupling     |
| 3   | Fuel tank               | 31  | Chamber bracket            | 59  | Valve cord        |
| 4   | Power cord              | 32  | Combustion chamber         | 60  | Motor             |
| 5   | Cable fastener          | 33  | Hook                       | 61  | Fan               |
| 6   | Oil leveler             | 34  | Photocell ass'y bracket    | 62  | Top bracket cover |
| 7   | Oil inlet filter holder | 35  | Air adjustment ring        | 63  | Top front cover   |
| 8   | Oil inlet filter        | 36  | Photocell ass'y            | 64  | Chimney connector |
| 9   | Tank cap shaft          | 37  | Thermostat bracket         | 65  | Side plate        |
| 10  | Sealing ring            | 38  | Re-set thermostat          | 66  | wheel axle        |
| 11  | Fuel tank cap           | 39  | Nozzle ass'y               | 67  | Feet pipe         |
| 12  | Breath cover            | 40  | Nozzle Adapter             | 68  | Cotter pin        |
| 13  | Oil suction pipe        | 41  | Swirl disc                 | 69  | Wheel             |
| 14  | Sealing ring            | 42  | Nozzle base plate          | 70  | Flat gasket       |
| 15  | Oil pipe union          | 43  | Screw nut                  | 71  | Screw nut         |
| 16  | Bottom casing           | 44  | Elbow connection           | 72  | Stell pipe plug   |
| 17  | Body support pipe       | 45  | Ignition needle            | 73  | Handle            |
| 18  | Ignition transformer    | 46  | Oil tube assembly          | 74  | Cable holder      |
| 19  | Power PCB1              | 47  | High voltage cable         | A-1 | Socket            |
| 20  | PCB support             | 48  | Air balance plate          | A-2 | Buckle            |
| 21  | Control panel           | 49  | Filter elbow connection    | A-3 | Socket cap        |
| 22  | Support bracket         | 50  | Oil pipe                   | A-4 | Plug              |
| 23  | On/off switch           | 51  | Filter                     | A-5 | Line              |
| 24  | Display PCB2            | 52  | Filter straight connection | A-6 | Bottom cover      |
| 25  | Display window          | 53  | Filter support             | A-7 | Fixing clip       |
| 26  | Fixing nut              | 54  | Air inlet grill            | A-8 | Top cover         |
| 27  | Thermostat knob         | 55  | Motor support              |     |                   |
| 28  | Air outlet cone         | 56  | Fuel pipe joint            |     |                   |

## Disposal

Always dispose of packing materials in an environmentally friendly manner and in accordance with the applicable local disposal regulations.



The icon with the crossed-out waste bin on waste electrical or electronic equipment is taken from Directive 2012/19/EU. It states that this device must not be disposed of with the household waste at the end of its life. You will find collection points for free return of waste electrical and electronic equipment in your vicinity. The addresses can be obtained from your municipality or local administration. You can also find out about other return options that apply for many EU countries on the website <https://hub.trotec.com/?id=45090>. Otherwise, please contact an official recycling centre for electronic and electrical equipment authorised for your country.

The separate collection of waste electrical and electronic equipment aims to enable the re-use, recycling and other forms of recovery of waste equipment as well as to prevent negative effects for the environment and human health caused by the disposal of hazardous substances potentially contained in the equipment.

### Fuel oil

The fuel oil must be drained from the device and collected.

Fuels are to be disposed of according to the national regulations.

## Declaration of conformity

Declaration of conformity in accordance with the EC Machinery Directive 2006/42/EC, Annex II, Part 1, Section A

We – Trotec GmbH – declare in sole responsibility that the product designated below was developed, constructed and produced in compliance with the requirements of the EC Machinery Directive in the version 2006/42/EC.

**Product model / product:** IDE 20, IDE 30, IDE 50, IDE 60, IDE 80

**Product type:** oil heater

**Year of manufacture as of:** 2026

### Relevant EU directives:

- 2011/65/EU
- 2012/19/EU
- 2014/30/EU
- 2015/863/EU

### Applied harmonised standards:

- EN 60335-1:2012/A15:2021
- EN 60335-2-102:2016

### Applied national standards and technical specifications:

- EN 60335-1:2012/A16:2023
- EN 62233:2008
- EN IEC 55014-1:2021
- EN IEC 55014-2:2021
- EN IEC 61000-3-2:2019/A1:2021
- EN IEC 61000-3-2:2019/A2:2024
- EN 61000-3-3:2013/A1:2019
- EN 61000-3-3:2013/A2:2021
- EN 13842:2004

### Manufacturer and name of the authorised representative of the technical documentation:

Trotec GmbH

Grebbeener Straße 7, D-52525 Heinsberg

Phone: +49 2452 962-400

E-mail: [info@trotec.de](mailto:info@trotec.de)

Place and date of issue:

Heinsberg, 18.05.2026

Joachim Ludwig, Managing Director

Trotec GmbH

Grebbener Str. 7  
D-52525 Heinsberg

☎ +49 2452 962-400

☎ +49 2452 962-200

✉ [info@trotec.com](mailto:info@trotec.com)

[www.trotec.com](http://www.trotec.com)