

TTR 400 / TTR 400 D / TTR 500 D

EN

ORIGINAL INSTRUCTIONS
DESICCANT DEHUMIDIFIER



Table of contents

Notes regarding the instructions 2

Safety 3

Information about the device 5

Transport and installation 7

Assembly and installation 7

Operation 8

Errors and faults 9

Maintenance 9

Harmful influences on rotors 11

Disposal 12

Technical annex 13

You can download the current version of the instructions and the EU declaration of conformity via the following link:



TTR 400



<https://hub.trotec.com/?id=39695>

TTR 400 D



<https://hub.trotec.com/?id=39696>

TTR 500 D





<https://hub.trotec.com/?id=39697>

Notes regarding the instructions

Symbols

 **Warning of electrical voltage**
This symbol indicates dangers to the life and health of persons due to electrical voltage.

 **Warning of hot surface**
This symbol indicates dangers to the life and health of persons due to hot surface.

 **Warning**
This signal word indicates a hazard with an average risk level which, if not avoided, can result in serious injury or death.

 **Caution**
This signal word indicates a hazard with a low risk level which, if not avoided, can result in minor or moderate injury.

Note
This signal word indicates important information (e.g. material damage), but does not indicate hazards.

 **Info**
Information marked with this symbol helps you to carry out your tasks quickly and safely.

 **Follow the manual**
Information marked with this symbol indicates that the instructions must be observed.

Safety

Read this manual carefully before starting or using the device. Always store the manual in the immediate vicinity of the device or its site of use.



Warning

Read all safety warnings and all instructions.

Failure to follow the warnings and instructions may result in electric shock, fire and / or serious injury.

Save all warnings and instructions for future reference.

This appliance can be used by children aged from 8 years and above and persons with reduced physical, sensory or mental capabilities or lack of experience and knowledge if they have been given supervision or instruction concerning use of the appliance in a safe way and understand the hazards involved.

Children shall not play with the appliance. Cleaning and user maintenance shall not be made by children without supervision.



Warning

Children of less than 3 years should be kept away unless continuously supervised.

Children aged from 3 years and less than 8 years shall only switch on/off the appliance provided that it has been placed or installed in its intended normal operating position and they have been given supervision or instruction concerning use of the appliance in a safe way and understand the hazards involved.

Children aged from 3 years and less than 8 years shall not plug in, regulate and clean the appliance or perform user maintenance.



Warning

This device is not equipped with a room temperature controller. Do not use the device in small rooms if persons are present who cannot leave the room independently and who are not under constant supervision.

- Do not use the device in potentially explosive rooms or areas and do not install it there.
- Do not use the device in aggressive atmosphere.
- Only put up the device in an upright, stable position on firm ground.
- Let the device dry out after a wet clean. Do not operate it when wet.
- Do not use the device with wet or damp hands.
- Do not expose the device to directly squirting water.
- Ensure sufficient lighting at the device.
- Never insert any objects or limbs into the running device.
- Do not cover or transport the device during operation.
- Do not sit on the device.
- This appliance is not a toy! Keep away from children and animals. Do not leave the device unattended during operation.
- Check accessories and connection parts for possible damage prior to every use of the device. Do not use any defective devices or device parts.
- Ensure that all electric cables outside of the device are protected from damage (e.g. caused by animals). Never use the device if electric cables or the power connection are damaged!
- The electrical connection must correspond to the specifications on the nameplate. Additionally, information regarding the electrical connection is provided in the technical annex.
- Insert the mains plug (if any) into a properly secured mains power socket.
- Observe the device's power input, cable length and intended use when selecting extensions to the power cable. Completely unroll extension cables. Avoid electrical overload.
- If you do not use the device for extended periods of time, switch the device off and disconnect it from the mains.
- Before maintenance, care or repair work disconnect the device from the mains and secure it against unauthorized restart.
- Before carrying out maintenance, care or repair work on the device, remove the mains plug from the mains socket. Hold onto the mains plug while doing so.
- Do not under any circumstances use the device if you detect damages on the mains plug or power cable. If the supply cord is damaged, it must be replaced by the manufacturer, its service agent or similarly qualified persons in order to avoid a hazard. Defective power cables pose a serious health risk!
- When positioning the device, observe the minimum distances from walls and other objects as well as the storage and operating conditions specified in the technical annex.
- Make sure that the air inlet and outlet are not obstructed.
- Make sure that the suction side is kept free of dirt and loose objects.
- Do not use the device in immediate proximity to curtains, beds or sofas.
- Do not place the device on combustible ground.
- Do not remove any safety signs, stickers or labels from the device. Keep all safety signs, stickers and labels in legible condition.

- Do not use this device near bathtubs, shower trays, swimming pools or other water containers. Risk of electric shock!
- Allow the device to cool down before transport and/or maintenance work.
- Only transport the device in an upright position.
- Do not use the device any more once it has been dropped.
- The device must not be positioned directly beneath a wall socket.

Intended use

The desiccant dehumidifiers of the TTR series are only to be used for dehumidifying atmospheric air. Any other use possibly exceeding the intended purpose is considered to be improper use.

Intended use comprises:

- observing all the information in the instructions
- compliance with the inspection and maintenance tasks
- observing the permissible operating and surrounding conditions according to the technical data (see Technical annex)

The following minimum requirements must be met:

- permissible ambient temperature: -20 °C to +40 °C
- relative humidity: max. 95 % non-condensing

After consultation with Trotec other operating conditions are possible with respectively modified versions.

Improper use

- Dehumidifiers are not suited for the installation on or the intake of fluids, e.g. from filled tanks, tubs or flooded installation areas.
- If supplying the system with contaminated air, the **"harmful influences on rotors"** must be observed!
- Any unauthorised modifications, alterations or structural changes to the device are forbidden.
- Any operation other than as described in this manual is prohibited. Non-observance renders all claims for liability and guarantee null and void.

Symbols on the device

Symbols	Meaning
	This symbol located on the device indicates that it is prohibited to place objects (such as towels, clothes etc.) above or directly in front of the device. In order to avoid overheating and fire hazards, the device must not be covered!

Personnel qualifications

People who use this device must:

- be aware of the dangers that occur when working with electric devices in damp areas.
- have read and understood the instructions, especially the Safety chapter.

Instructed person

Instructed persons have been informed of the tasks they were entrusted with as well as of potential hazards resulting from inappropriate behaviour. They are allowed to operate and transport the device and perform simple maintenance activities (cleaning the housing, cleaning the fan).

The device is to be maintained and looked after by instructed personnel.

Residual risks



Warning of electrical voltage

Work on the electrical components must only be carried out by a qualified electrician!



Warning of electrical voltage

Make sure to de-energize the device before starting work on electrical components.
Hold onto the mains plug while pulling the power cable out of the mains socket.



Warning of hot surface

Some parts of this product can become very hot and cause burns. Particular attention has to be given where children and vulnerable people are present!



Warning

Dangers can occur at the device when it is used by untrained people in an unprofessional or improper way! Observe the personnel qualifications!



Warning

The device is not a toy and does not belong in the hands of children.



Warning

Risk of suffocation!
Do not leave the packaging lying around. Children may use it as a dangerous toy.



Warning

In order to avoid overheating and fire hazards, the device must not be covered!

Note

Do not operate the device without an air filter inserted into the air inlet!
Without the air filter, the inside of the device will be heavily contaminated. This could reduce the performance and result in damage to the device.

Note

Dirt accumulating inside the rotor can substantially reduce the dehumidification performance or damage the rotor beyond repair.

Supplying the system with contaminated air might damage the rotor. Observe the information regarding "Harmful influences on rotors".

Note

After a power failure the device will restart automatically provided that it was not switched off in the meantime. This behaviour is desired and necessary to ensure operation with little supervision.

Behaviour in the event of an emergency

1. Switch off the device.
2. In an emergency, disconnect the device from the mains feed-in: Hold onto the mains plug while pulling the power cable out of the mains socket.
3. Do not reconnect a defective device to the mains.

Information about the device

General description

Dehumidifiers operating on the desiccant principle are used to tackle drying tasks in the field of process engineering, air-conditioning, on construction sites and for the dehumidification of production and storage facilities, where a particularly low humidity level is required over a broad temperature range.

The desiccation technique enables the safe and economic operation even at low operating temperatures.

The desiccant dehumidifier works with a desiccant wheel (rotor), which is composed of layers of smooth and corrugated non-woven fabric with chemically bonded silica gel. Thus created is a honeycomb structure with a large number of axial air ducts with a large surface and direct connection to the inner pore structure of the silica gel.

On account of the desiccant wheel's good mechanical and physical properties no silica gel is discharged. It may be supplied with saturated air with a relative humidity of up to 100 % but not with water drops. The rotor is incombustible.

Design

The general structure of a dehumidification unit is as follows:

- fans for air transport
- at least two different sectors for guiding the process air (to be dehumidified) and the regeneration air (moist exhaust air)
- rotor desiccant wheel for the dehumidification with silica gel
- drive unit with gear motor, toothed belt pulley and toothed belt
- heater battery for heating regeneration air

During dehumidification the desiccant wheel turns continuously at a low speed (depending on the configuration 3 to 30 rotations per hour). Via the sectors the desiccant wheel is simultaneously charged with the process and regeneration air so it can constantly absorb and release moisture.

Functional principle TTR 400

Process air

The air to be dehumidified is sucked in by means of a fan and divided into two air flows: process air (4) and regeneration air (5).

The process air (4) flows through the desiccant wheel's dehumidification sector (1). In doing so, the contained moisture is withdrawn by the sorbent (silica gel) and retained (desiccation).

After having passed the sector, the now dried air (6) is emitted to the room.

Regeneration air

The second air current (5) is guided through the purging sector as regeneration air. This sector serves for the recovery of the desiccation heat generated during dehumidification.

At the same time the desiccant wheel is cooled leading to a reduced energy input and improved dehumidification performance – especially at lower dew points.

Subsequently, the air current is led through a heater battery (7) and heated to approx. 100 to 120 °C (depending on the intake temperature). Simultaneously, the relative humidity is extremely reduced.

In passing through the regeneration sector (2), the thus prepared air now again absorbs the moisture retained by the silica gel (desorption). Then the extremely humid regeneration air (8) is discharged to the outside via the humid air outlet.

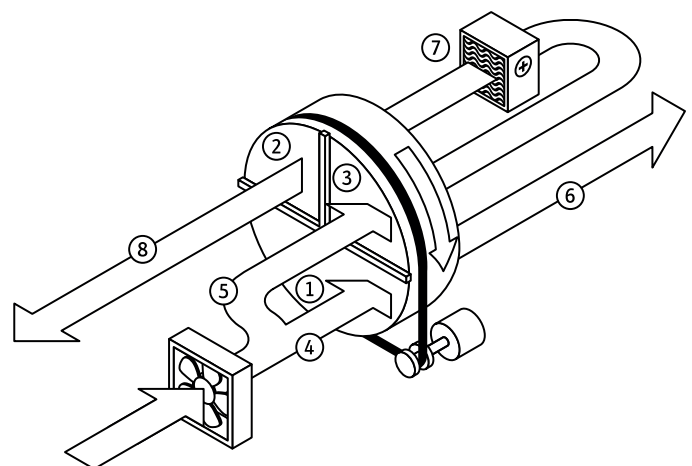

Functional principle TTR 400 D / TTR 500 D

Process air

The air to be dehumidified is sucked in by means of a fan. The process air (4) flows through the desiccant wheel's dehumidification sector (1).

In doing so, the contained moisture is withdrawn by the sorbent (silica gel) and retained (desiccation). Due to physical processes the temperature of the dry air (6) increases. Later the dried air flows towards the dry air outlet.

Regeneration air

The regeneration air (5) is also sucked in with its own fan and guided through the purging sector (3). During dehumidification the desiccant wheel warms up as a result of the released desiccation heat and the regeneration heat. The purging sector (3) serves the purpose of heat recovery and for cooling the desiccant wheel, leading to a reduced energy input and improvement of the dehumidification performance – especially at lower dew points. Whilst flowing through the heater battery (7) the air is heated to approx. 100 °C to 120 °C (depending on the intake temperature) and at the same time the relative humidity is extremely reduced.

In passing through the regeneration sector (2), the thusly prepared air now again absorbs the moisture retained by the silica gel (desorption). Then the extremely humid regeneration air (8) is discharged to the outside via the humid air outlet.

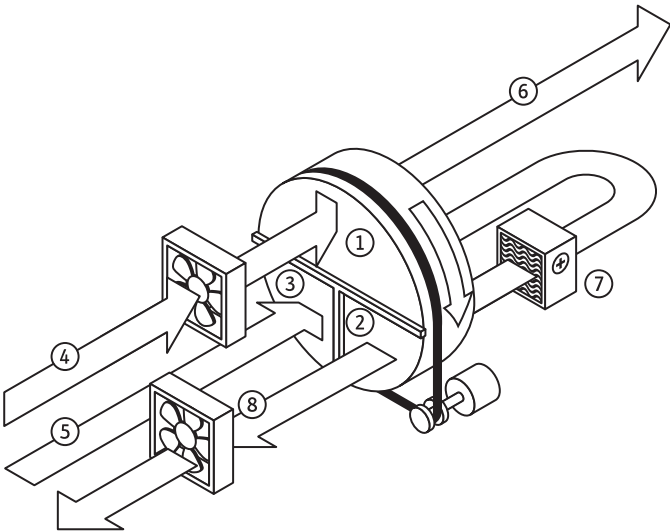

Device depiction

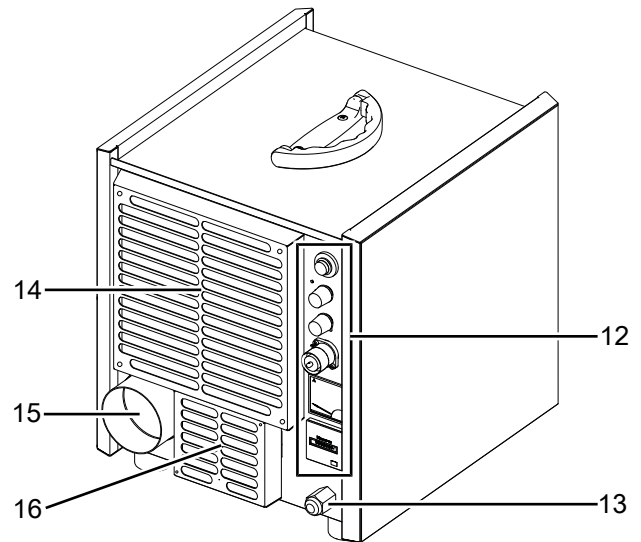
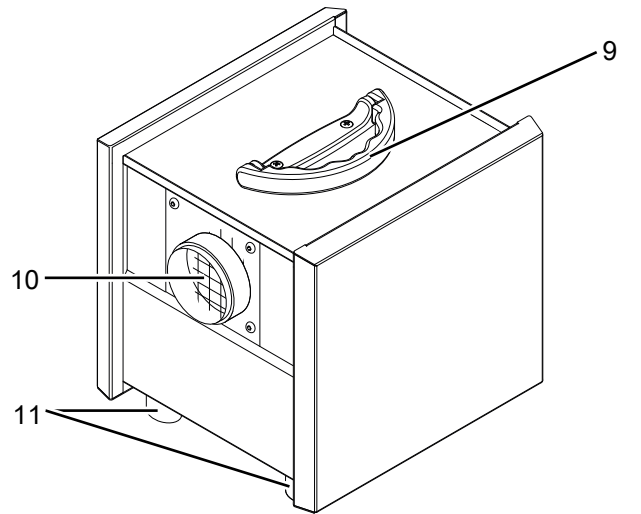

No.	Designation
9	Carrying handle
10	Dry air outlet
11	Feet
12	Operating element
13	Connection cable
14	Air inlet grid with coarse particulate air filter
15	Humid air outlet
16	Air inlet grid with coarse particulate air filter

Optional accessories

Further accessories are available for operating the dehumidifier:

- Hose adapter to be assembled to the air inlet grid (16)
- Air filter box with pipe/hose connection for Z-line filters G4 to F9
- Hygrostat with Tichel plug for connection socket (20)
- Combined counter for operating hours and energy consumption

For more information on features and order conditions please contact the Trotec customer service.

Transport and installation

To make the device easier to transport, it is fitted with a carrying handle.

Note

If you store or transport the device improperly, the device may be damaged.

Note the information regarding transport and storage of the device.

Note

Device may be damaged by vibration!

Excessive vibrations can result in damage to the device.

Therefore, protect it against excessive vibrations, e.g. abrupt positioning or dropping, during transport. Always protect the device from slipping during transport.

Only lift or carry the device at the provided fixtures.

Positioning

- Inside the room to be dehumidified:
 - The device works in recirculation mode, the regeneration air must be fed from outside and the regeneration exhaust air must be led outside.
- Outside the room to be dehumidified:
 - The device can be connected in either recirculation or ventilation mode. A connection of the dry air to the room to be dehumidified must be established.

Storage

When the device is not being used, observe the following storage conditions:

- dry and protected from frost and heat
- in an upright position where it is protected from dust and direct sunlight
- with a cover to protect it from invasive dust, if necessary
- When not in use, always disconnect the device from the power supply.
- Up to 4 devices may be stacked on top of one another to save space.
- Secure stacks against toppling over.

Assembly and installation

- The pipes or hoses used must be designed for the available static compression of the fans. The air hoses should preferably be laid in a straight line and at full length.
- The regeneration exhaust air line must be laid with a slight decline so that possibly accumulating condensate cannot flow back into the device or obstruct the air flow. If an incline cannot be avoided, it is necessary to establish a condensate drain. As preventive action, the exhaust air pipe may be insulated.
- To prevent an immediate neutralization with the moist exhaust air, the humid air outlet should be guided away with a minimum distance of approx. 1 m in case of direct-intake devices.

Scope of delivery

The scope of delivery of the device contains:

- 1 x Dehumidifier
- 1 x Connection cable
- 1 x Instructions

There are further accessories optionally available, which can be obtained from the Trotec customer service.

Default settings

Generally, air conditioning units are equipped with one or more fans, which must be overdimensioned accordingly to overcome resistances caused by pipes or appliances. Usually, their speed cannot be adjusted. In order to set the air quantities required for the application, a hydraulic compensation must be carried out by means of throttle valves installed in front of or behind the fan. This, however, results in an unnecessary and often considerable increase in the noise level and energy consumption.

This device has one integrated **variable-speed high-performance fan** for each air current supplying the nominal volumetric flow rates of the dry air and regeneration air at maximum speed despite the air hoses (approx. 10 m length each) being connected.

Moreover, for heating the regeneration air, the device has an installed heater battery generating heat by means of ceramic PTC semiconductor elements. The latter have a maximum surface temperature of approx. 240 °C, which they try to maintain. The temperature-dependent resistance, which rises rapidly as of a certain value (Curie temperature) when the heat reduction decreases, causes self-regulating effects of the heating current consumption, i.e. when the air temperature rises and/or the air volume decreases, the current consumption is reduced (and vice versa). Furthermore, a destruction caused by overheating, for instance due to a lack of regeneration air, can be virtually ruled out.

In order to reach a preferably **low outlet humidity level** with a minimum dry air volume or to achieve the **highest dehumidification performance** with a maximum dry air volume, it is important to set the regeneration air volume correctly. The air volume must be adjusted until the value specified as **optimum heating current** is indicated on the ammeter.

For all other applications with low requirements regarding the dehumidification performance and dry air volume, the fan speed may be decreased until the value specified as **minimum heating current** is indicated on the ammeter. This allows you to achieve very good dehumidification results at minimum energy input.

Operation

Operating element

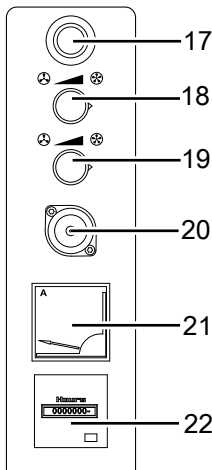

No.	Designation	Meaning
17	Mains switch	Switching the device on and off
18	Dry air speed controller	Setting the fan speed for dry air
19	Humid air speed controller (TTR 400 D / TTR 500 D)	Setting the fan speed for humid air
20	Socket for external hygrostat	Connection for hygrostat operation
21	Ammeter	Indication of electric current
22	Operating hours counter	Indication of operating hours

Switch-on

Switch the device on by actuating the mains switch (17). The integrated indicator light lights up.

Switch-off

Switch the device off by actuating the mains switch (17). The integrated indicator light goes off.

Remote operation

Switch the device on by actuating the mains switch (17). The integrated indicator light lights up.

Connect an external switch or external switching device, e.g. a hygrostat or timer, to the socket (20) with the suitable Tichel plug (optional accessory). Always observe the information contained in the circuit diagram (see Technical annex).

All electrical loads are now switched on or off by the external switch as needed. The indicator light of the mains switch remains illuminated regardless of the switching state and indicates that the control unit is activate. In hygrostat operation, air circulation may in some cases be necessary at the point of moisture measurement. In this case, the fan can be configured for permanent operation by replugging a plug contact at the integrated relay. This operation may only be carried out by an electrically skilled person. If required, please contact the Trotec customer service.

Adjusting the air volume

Using the speed controllers (18) and (19) you can adjust the speed of the fans.

1. In order to increase the air volume, turn the speed controller to the right.
2. In order to decrease the air volume, turn the speed controller to the left.

Errors and faults

Error	Diagnosis	Potential cause	Remedy
No dehumidification	Dry air shows no temperature increase	Rotor drive defective	Check rotor drive and have it repaired if necessary
	Ammeter indicates strongly deviating values	Heating defective	Renew heating
	Ammeter indicates deviating values	Regeneration air current is insufficient	Check for free air flow, check fan, clean or renew air filter

Service and repair



Warning

Risk of death due to improper repair!
 Never try to make any modifications or repairs on the device. Unauthorised modifications can lead to serious injuries or death. Have a certified specialist workshop perform the repair work.
 Repair work may only be carried out by trained specialist staff!

In case of a technical problem please try to rule out handling or application errors before contacting our customer service.

For further questions regarding the function and operation of the dehumidifier as well as for more information in the case of an error or else for warranty issues we are of course always happy to be of service.

Please contact:

Trotec GmbH
 Grebbener Straße 7
 D-52525 Heinsberg

Tel.: +49 (0) 2452 / 962-400

Fax.: +49 (0) 2452 / 962-200

E-mail: info@trotec.de

www.trotec.de

Maintenance

Activities required before starting maintenance



Warning of electrical voltage

Do not touch the mains plug with wet or damp hands.

- Switch the device off.
- Hold onto the mains plug while pulling the power cable out of the mains socket.



Warning of electrical voltage

Tasks which require the housing to be opened must only be carried out by authorised specialist companies or by Trotec.

Care

Note

Device may be damaged by improper cleaning!
 Only clean the inside with a damp cloth or with compressed air. Do not bring any fluids into the inside of the device!

The surface of the device housing is finished with an easy-to-clean powder coating. Therefore, dirt can only adhere poorly and can be easily removed with a damp cloth.

Cleaning of the inside and integrated components may only be carried out by trained personnel or by the Trotec customer service.

Maintenance

Note

Device may be damaged by improper handling!
 Cleaning, maintenance and repair work on electrical and mechanical components may only be carried out by trained personnel or by the Trotec customer service!

The device is designed for long hours of operation with minimum maintenance effort. Safe operation of the device requires all built-in components to be checked and cleaned **after 6 months at the latest or after every 4,000 operating hours** as well as all damaged components to be replaced.

Filter change

Warning

Risk of injury due to fan!
 Make sure to switch the device off and secure it against unintentional start-up before you remove the air filter – especially if the fan's inlet opening is freely accessible.

The filter change intervals depend on the degree of air pollution and the filter quality. Dirty filters impair the performance ability of the dehumidifier. For this reason, they should be checked **once a week (or daily in construction areas)** and cleaned or replaced if required.

1. Pull the filter cover off with a slight jerk and remove the filter mat.

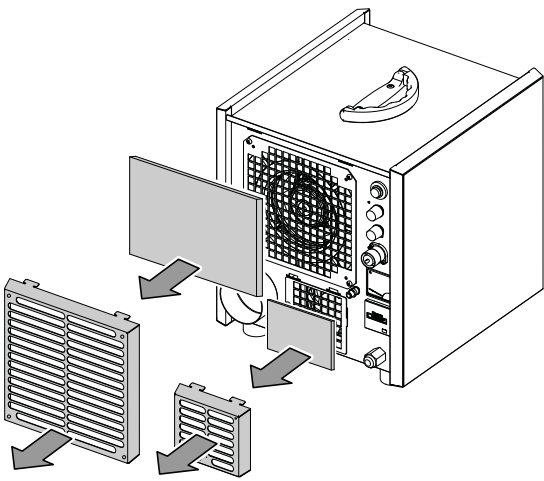

2. Clean the filter using a slightly damp, soft, lint-free cloth. If the filter is heavily contaminated, clean it with warm water mixed with a neutral cleaning agent.

Info

Ex factory the device comes equipped with a reusable filter mat (PPI30). It can be cleaned by tapping and washing it out.

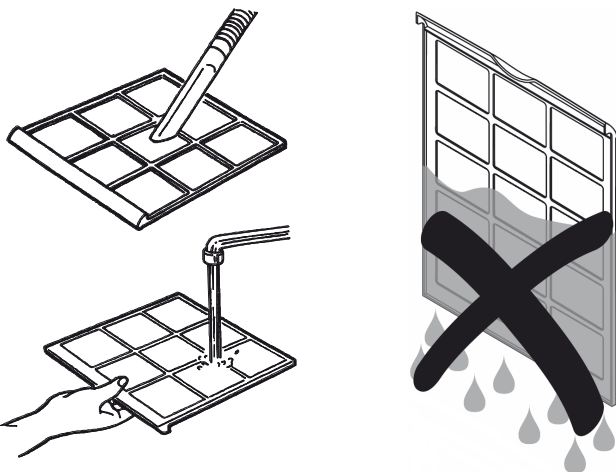

3. Allow the filter to dry completely. Do not insert a wet filter into the device!

Note

Device may be damaged by liquid. Before reinserting the air filter, make sure it has dried completely. Otherwise there is a risk of the fan sucking in liquid leading to a short circuit and consequential damage.

4. Reinsert the air filter into the device.

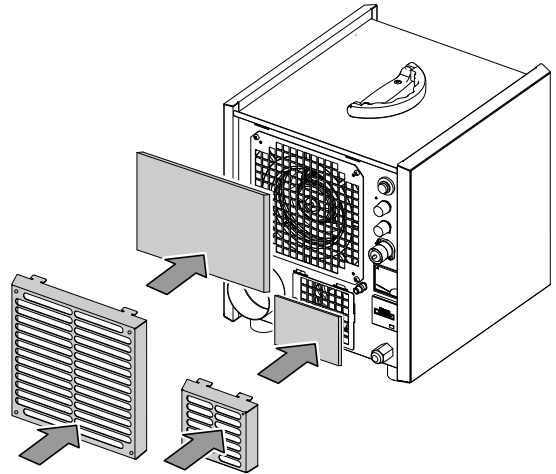

Harmful influences on rotors

Some of the substances and compounds listed below are typical examples for substances dissolving the honeycombed silica gel rotors or else negatively affecting the dehumidification performance.

The sorption rotor should not be charged with air which is contaminated with the following or similar substances. Even minor concentrations in the air can have lasting harmful effects on the rotor material and the sorption capacity.

The listed substances remain in the rotor material or the rotor elements and can bring about the following effects:

- Reduced performance owing to the clogging of the silica gel's pores
- Reduced performance owing to the chemical reaction with the silica gel

Moreover, the intake air must not contain any particles of substances with a melting point of less than 200 °C.

A) Inorganic substances (examples)

No.	Substances	Chemical formula	Effects
1	lithium chloride	LiCl	reduced productivity of the silica gel ¹⁾
2	sodium hydroxide	NaOH	destruction of the silica gel structure
3	potassium hydroxide	KOH	destruction of the silica gel structure
4	sodium chloride	NaCl	reduced productivity of the silica gel ¹⁾
5	potassium chloride	KCl	reduced productivity of the silica gel ¹⁾
6	calcium chloride	CaCl ₂	reduced productivity of the silica gel ¹⁾
7	magnesium chloride	MgCl ₂	reduced productivity of the silica gel ¹⁾
8	ammonia	NH ₃	destruction of the silica gel structure
9	hydrofluoric acid	HF	destruction of the mechanical strength of the rotor material
10	aluminium chloride	AlCl ₃	reduced productivity of the silica gel ¹⁾
11	sea water		reduced productivity of the silica gel ¹⁾
12	steam with a high temperature		destruction of the silica gel structure
13	softener		clogging of the silica gel's pores
14	strong acids	pH ≤ 2...3	destruction of the mechanical strength of the rotor material
15	bases	pH ≥ 7...8	destruction of the sorption capacity of the silica gel
16	amines	R-NH ₂	reduced productivity of the silica gel ¹⁾

B) Organic substances (examples)

The solvents or volatiles listed below have a high boiling point and a low vapour pressure. Provided these substances are adsorbed by silica gel, they remain in the material on a permanent basis.

No.	Substances	Chemical formula	Effects
1	oil mist		clogging of the silica gel's pores
2	cyclohexanone	C ₆ H ₁₀ O	reduced productivity of the silica gel ¹⁾
3	isopropyl alcohol	CH ₃ H ₈ O	reduced productivity of the silica gel ¹⁾
4	o-xylene	C ₈ H ₁₀	reduced productivity of the silica gel ¹⁾
5	m-xylene	C ₈ H ₁₀	reduced productivity of the silica gel ¹⁾
6	p-xylene	C ₈ H ₁₀	reduced productivity of the silica gel ¹⁾
7	phenol	C ₆ H ₅ OH	reduced productivity of the silica gel ¹⁾
8	o-dichlorobenzenes	C ₆ H ₄ Cl ₂	reduced productivity of the silica gel ¹⁾
9	methyl bromide	CH ₃ Br	reduced productivity of the silica gel ¹⁾
10	glycerin	C ₃ H ₈ O ₃	reduced productivity of the silica gel ¹⁾

¹⁾ Reduces the internal pore surface of the silica gel leading to a loss of performance.

Disposal



The icon with the crossed-out waste bin on waste electrical or electronic equipment stipulates that this equipment must not be disposed of with the household waste at the end of its life. You will find collection points for free return of waste electrical and electronic equipment in your vicinity. The addresses can be obtained from your municipality or local administration. For further return options provided by us please refer to our website www.trotec24.com.

The separate collection of waste electrical and electronic equipment aims to enable the re-use, recycling and other forms of recovery of waste equipment as well as to prevent negative effects for the environment and human health caused by the disposal of hazardous substances potentially contained in the equipment.

Technical annex
Technical data

Parameter	Value*		
	TTR 400	TTR 400 D	TTR 500 D
Article number	1.110.000.020	1.110.000.021	1.110.000.025
EAN number	4.052.138.007.488	4.052.138.007.594	4.052.138.007.495
Dehumidification capacity	1.2 kg/h	1.6 kg/h	2.2 kg/h
Operating range, dry air	130 to 450 m ³ /h	130 to 450 m ³ /h	180 to 550 m ³ /h
Nominal dry air flow rate / static pressure	350 m ³ /h / 150 Pa	350 m ³ /h / 200 Pa	480 m ³ /h / 150 Pa
Nominal humid air flow rate / static pressure	50 m ³ /h / 80 Pa	65 m ³ /h / 80 Pa	80 m ³ /h / 80 Pa
Intake temperature	-15 °C to +35 °C	-15 °C to +35 °C	-15 °C to +35 °C
Ambient temperature	-20 °C to +40 °C	-20 °C to +40 °C	-20 °C to +40 °C
Electrical connection	200–240 V / 50/60 Hz	200–240 V / 50/60 Hz	200–240 V / 50/60 Hz
Max. current consumption	7.0 A	7.3 A	10.0 A
Heating current min. / opt. / max.	4.5 / 5.5 / 6.0 A	6.0 / 7.5 / 8.5 A	7.0 / 8.5 / 10.5 A
Length approx.	400 mm	400 mm	450 mm
Width approx.	350 mm	350 mm	400 mm
Height approx.	405 mm	405 mm	455 mm
Weight	17 kg	20 kg	25 kg
Dry air connection	125 mm	125 mm	125 mm
Humid air connection	80 mm	80 mm	80 mm
Sound pressure level (distance 1 m)	63 dB(A)	63 dB(A)	74 dB(A)
* based on 20 °C / 60 % RH			

Circuit diagram TTR 500 D

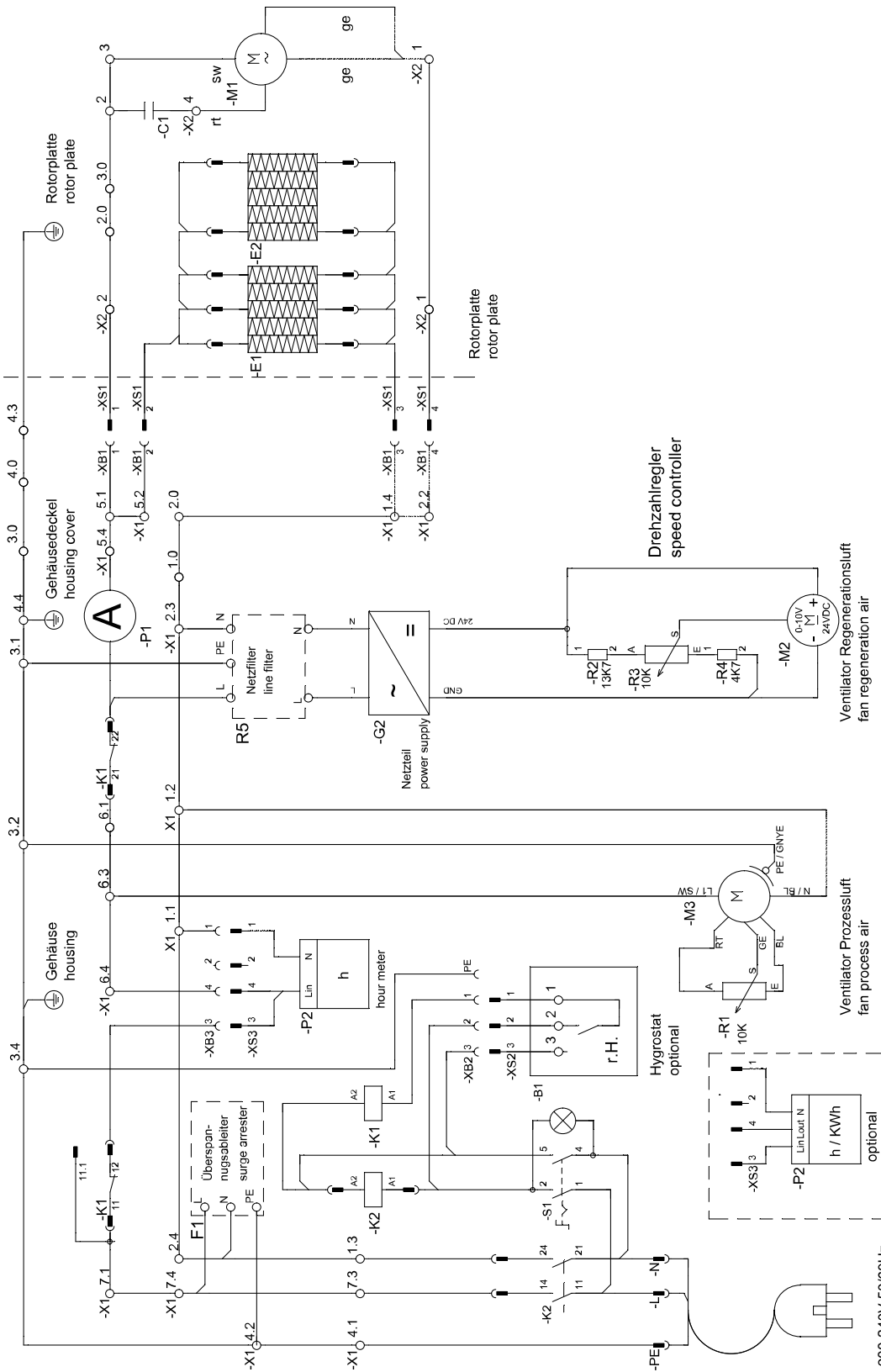

200-240V 50/60Hz

<p>© TROTEC GmbH & Co.KG, Grebbener Str. 7, D-52525 Heinsberg Weitergabe sowie Verfügbarmachung dieser Unterlagen, Verwertung und Mitteilung ihres Inhalts ist nicht gestattet, soweit nicht ausdrücklich zugestanden. Zuwidergehungen verpflichten zu Schadensersatz. Copying of this Document, and giving it to others and the use or communication of the contents thereof, are forbidden without express authority. Offenders are liable to the payment of damages.</p>	Dtl. 13.05.2019 Gez. U. Samplatzki Gepr.	TTR500D	Zeichn. Nr.: EEA-100-0174-05 Ausführung: TTR500D
	Rev. 0419		Blatt 1

Dimensions TTR 400

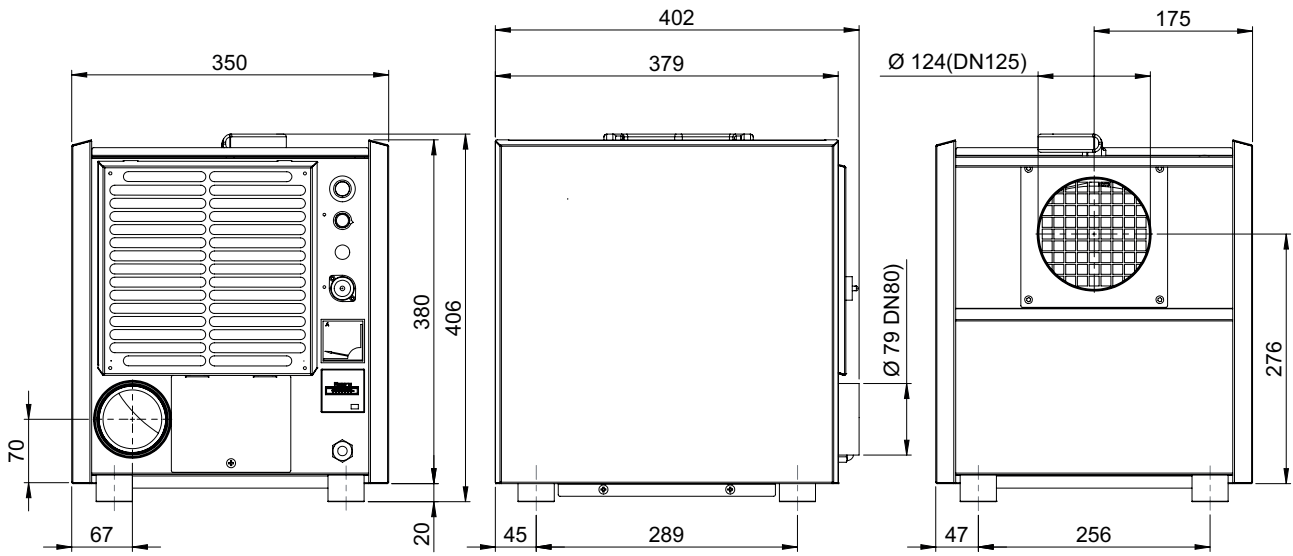

Dimensions TTR 400 D

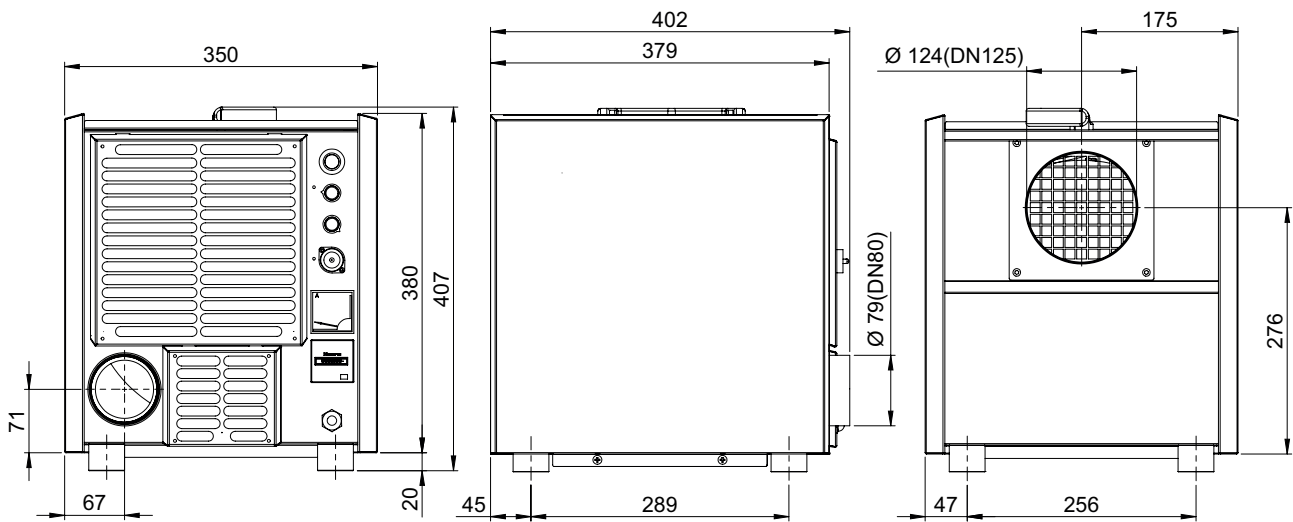

Dimensions TTR 500 D

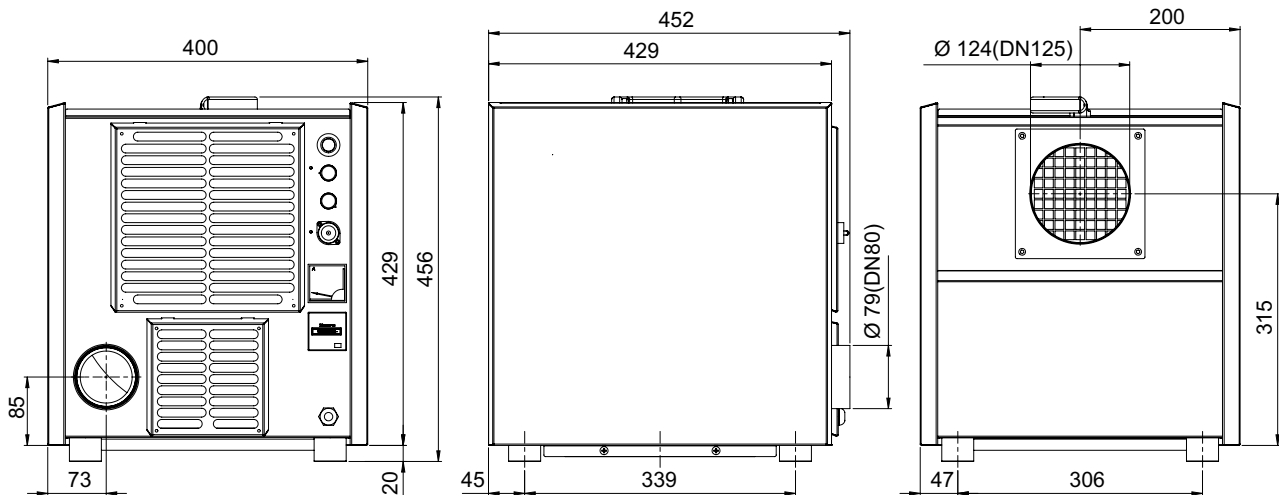

Spare parts drawing and list
TTR 400



Info

The position numbers of the spare parts differ from those describing the positions of the components mentioned in these instructions.

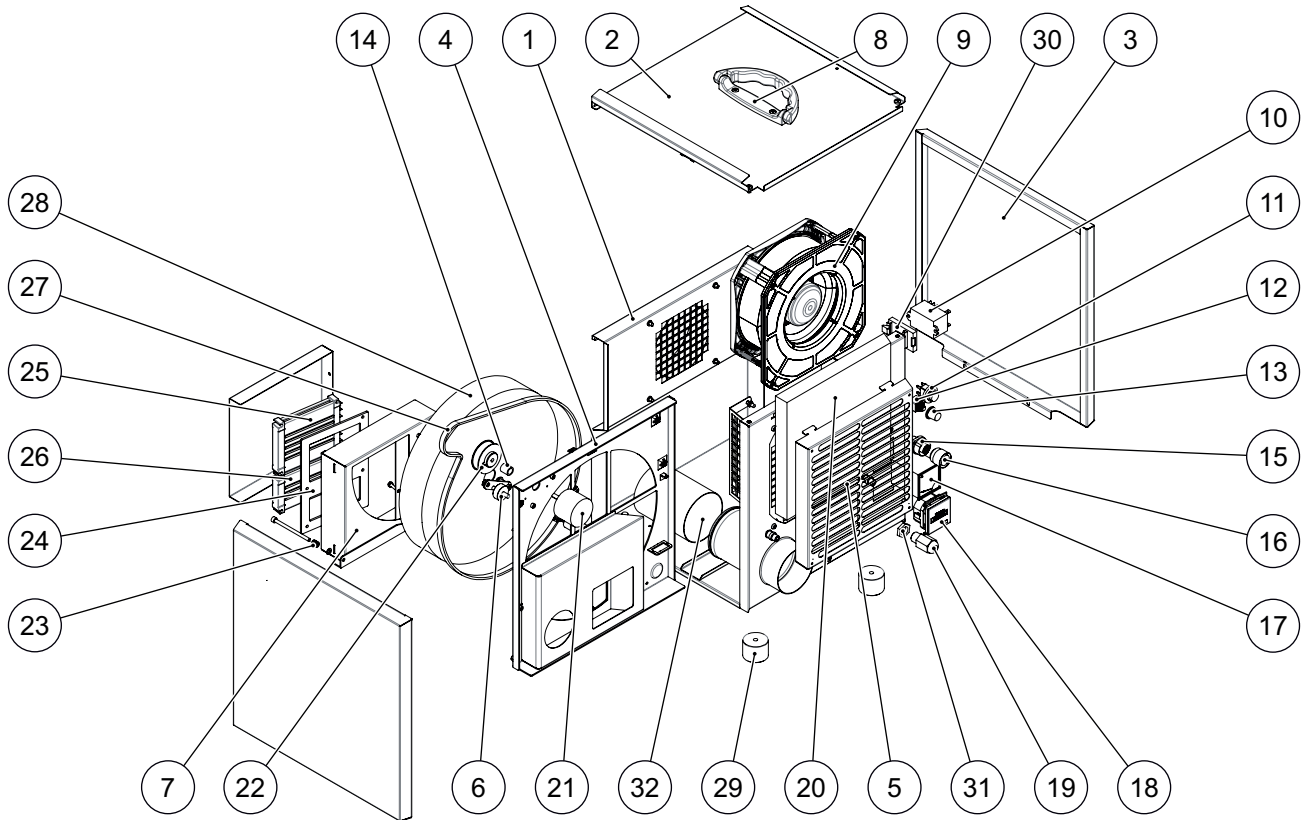

Item	Designation	Article number	Item	Designation	Article number
1	Basic housing	P 1000 1276	17	Ammeter	P 1000 0179
2	Cover	P 1000 1276	18	Operating hours counter	P 1000 1137
3	Panel	P 1000 1276	19	Cable bushing	P 1000 1247
4	Rotor cassette	P 1000 1276	20	Filter mat	P 1000 0671
5	ADS filter hood	P 1000 1276	21	Gear motor	P 1000 1038
6	Rubber tensioner	P 1000 1059	22	Toothed belt pulley	P 1000 0279
7	Heating frame	P 1000 1276	23	Pressure spring	P 1000 1055
8	Handle	P 1000 1246	24	Heating plate	P 1000 0273
9	Fan	P 1000 0534	25	Heating element	P 1000 7148
10	Relay	P 1000 0195	26	Heating element	P 1000 1182
11	Switch	P 1000 1376	27	Toothed belt	P 1000 1065
12	Potentiometer	P 1000 1751	28	Rotor	P 1000 1036
13	Rotary button for potentiometer	P 1000 1250	29	Foot	P 1000 0425
14	Needle bush	P 1000 1061	30	Mounting clip for relay	P 1000 0196
15	Connection socket	P 1000 1049	31	Lock nut for cable bushing	P 1000 1248
16	Protective cap	P 1000 1053	32	Exhaust air hose	P 1000 1069

Spare parts drawing and list TTR 400 D



Info

The position numbers of the spare parts differ from those describing the positions of the components mentioned in these instructions.

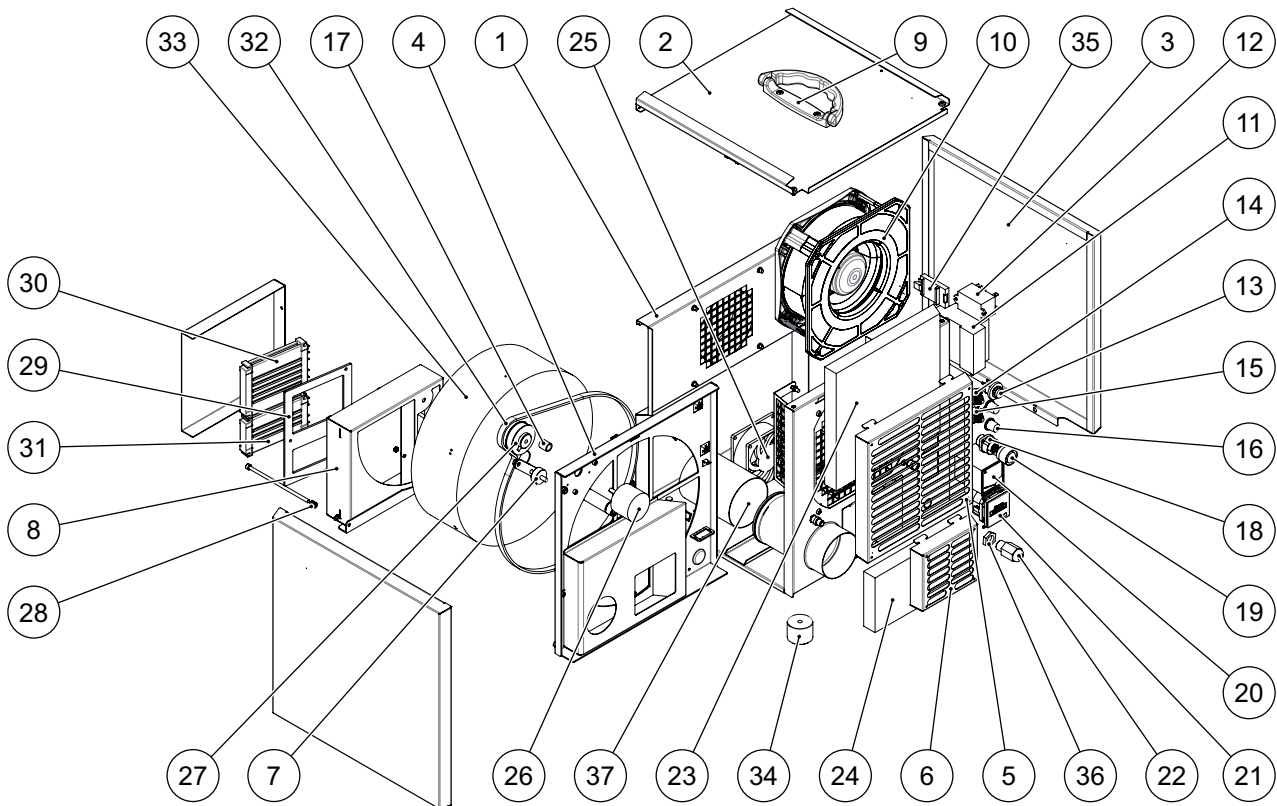

Item	Designation	Article number	Item	Designation	Article number
1	Basic housing	P 1000 1276	20	Ammeter	P 1000 0179
2	Cover	P 1000 1276	21	Operating hours counter	P 1000 1137
3	Panel	P 1000 1276	22	Cable bushing	P 1000 1247
4	Rotor cassette	P 1000 1276	23	Filter mat	P 1000 0671
5	ADS filter hood	P 1000 1276	24	Filter mat	P 1000 0672
6	REG filter hood	P 1000 1276	25	Fan	P 1000 0536
7	Rubber tensioner	P 1000 1059	26	Gear motor	P 1000 1160
8	Heating frame	P 1000 1276	27	Toothed belt pulley	P 1000 0279
9	Handle	P 1000 1246	28	Pressure spring	P 1000 1055
10	Fan	P 1000 0534	29	Heating plate	P 1000 0273
11	Power adapter	P 1000 1208	30	Heating element	P 1000 7148
12	Relay	P 1000 0195	31	Heating element	P 1000 1182
13	Switch	P 1000 1376	32	Toothed belt	P 1000 1065
14	Potentiometer	P 1000 1751	33	Rotor	P 1000 1216
15	Speed controller	P 1000 0291	34	Foot	P 1000 0425
16	Rotary button for potentiometer	P 1000 1250	35	Mounting clip for relay	P 1000 0196
17	Needle bush	P 1000 1061	36	Lock nut for cable bushing	P 1000 1248
18	Connection socket	P 1000 1049	37	Exhaust air hose	P 1000 1069
19	Protective cap	P 1000 1053			

Spare parts drawing and list
TTR 500 D



Info

The position numbers of the spare parts differ from those describing the positions of the components mentioned in these instructions.

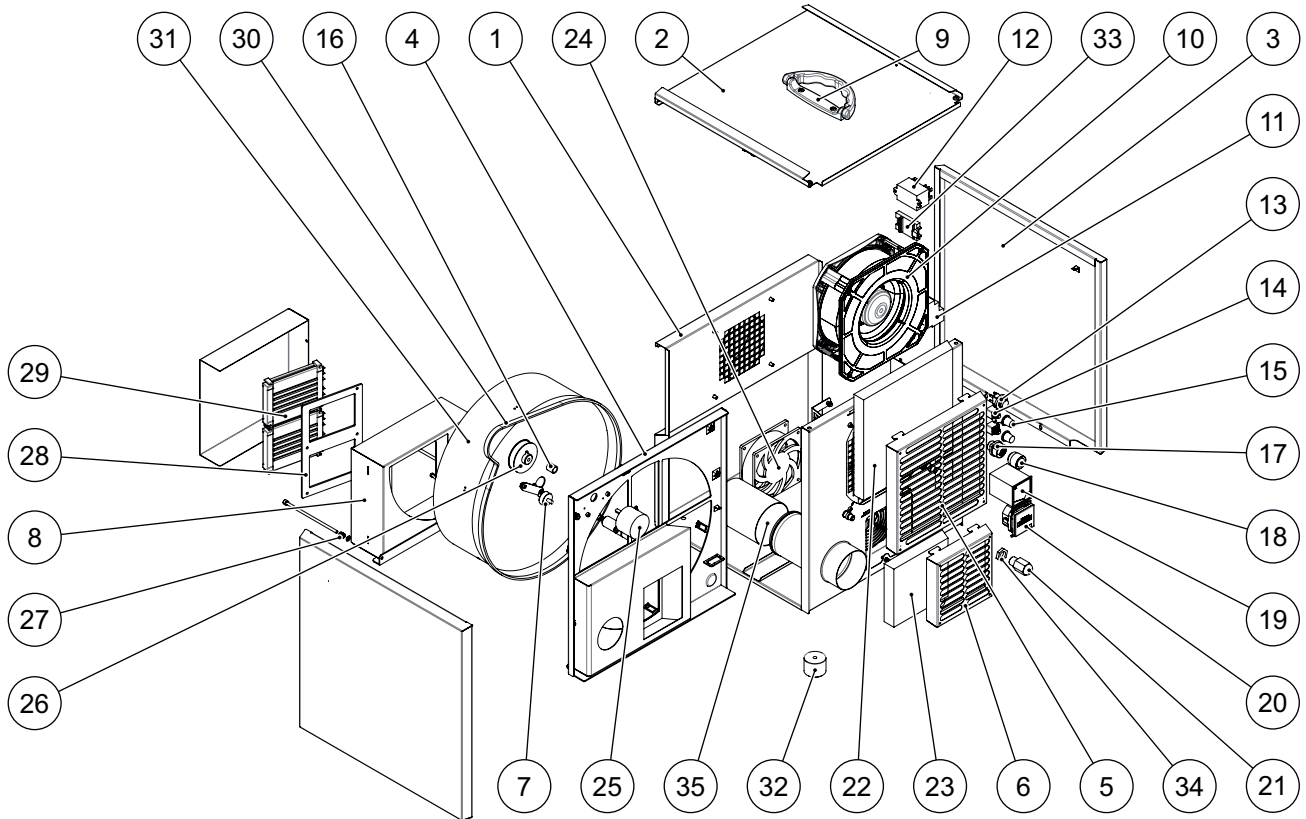

Item	Designation	Article number	Item	Designation	Article number
1	Basic housing	P 1000 1277	19	Ammeter	P 1000 1234
2	Cover	P 1000 1277	20	Operating hours counter	P 1000 1137
3	Panel	P 1000 1277	21	Cable bushing	P 1000 1247
4	Rotor cassette	P 1000 1277	22	Filter mat	P 1000 0671
5	ADS filter hood	P 1000 1277	23	Filter mat	P 1000 0673
6	REG filter hood	P 1000 1277	24	Fan	P 1000 1745
7	Rubber tensioner	P 1000 1059	25	Gear motor	P 1000 1160
8	Heating frame	P 1000 1277	26	Toothed belt pulley	P 1000 0278
9	Handle	P 1000 1246	27	Pressure spring	P 1000 1055
10	Fan	P 1000 0534	28	Heating plate	P 1000 0274
11	Power adapter	P 1000 1208	29	Heating element	P 1000 7148
12	Relay	P 1000 0195	30	Toothed belt	P 1000 1262
13	Switch	P 1000 1376	31	Rotor	P 1000 1215
14	Potentiometer	P 1000 1751	32	Foot	P 1000 0425
15	Rotary button for potentiometer	P 1000 1250	33	Mounting clip for relay	P 1000 0196
16	Needle bush	P 1000 1061	34	Lock nut for cable bushing	P 1000 1248
17	Connection socket	P 1000 1049	35	Exhaust air hose	P 1000 1069
18	Protective cap	P 1000 1053			

Trotec GmbH

Grebener Str. 7
D-52525 Heinsberg

☎ +49 2452 962-400

☎ +49 2452 962-200

✉ info@trotec.com

www.trotec.com