

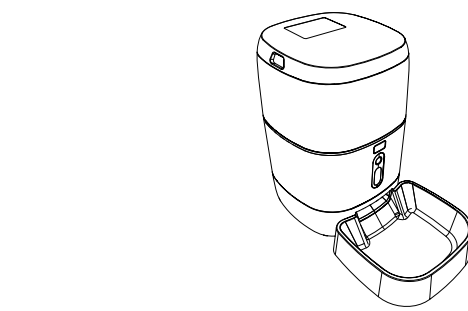

Catalogue

Please read this manual carefully before use to ensure safe use of the intelligent automatic feeder.



Feeder (subject to the actual product)

List of accessories (subject to the actual product)

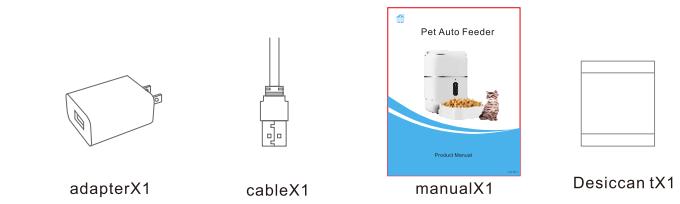

Product Introduction

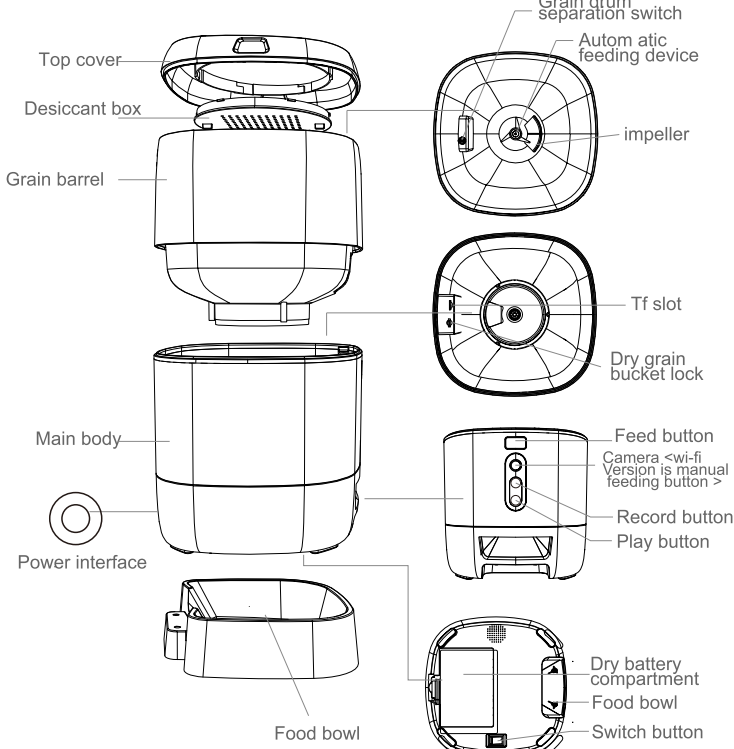

Battery use instructions: When the external power fails, the device will automatically enable the installed battery to power the device. (Note: the device cannot charge the battery)

Operation Guide

1. The first use

- (1)Open the top cover of the feeder and remove the power cord adapter from the bucket.
- (2)Plug the power cord into the power connector on the rear of the main unit and connect the adapter to power.
- (3)Place the main unit in a horizontal position and the food bowl is installed at the corresponding position of the main unit.
- (4)Add pet dry food to the feeder bucket.
- (5)The desiccant is placed in the desiccant box by default. Please replace it regularly for long-term use (do not use cleaning)
- (6)The battery compartment can be installed with 3sections of No. 1 battery for manual feeding when there is no electricity (optional).
- (7)Bind the feeder to the Smart Life app to set up the feeding and planning of the pet.

2. The function description

Feed button: Short press to eat one, long press for 5 seconds to restore the factory settings.
Record button: Press and hold the "Record button" to record the sound to remind the pet to eat before feeding.
Play button: Plays the recorded sound.
power switch :turn ON/OFF feeder
Battery Slot: Install 3 pcs D batteries can supply power.

3. Bind Smart Life APP

3.1:APP download and installation
Scan the QR code below to download the Smart Life app and complete the installation.



3.2 . Regis-tered APP

Open the installed smart life App and follow the prompts to register

3.3. Quick Configuration

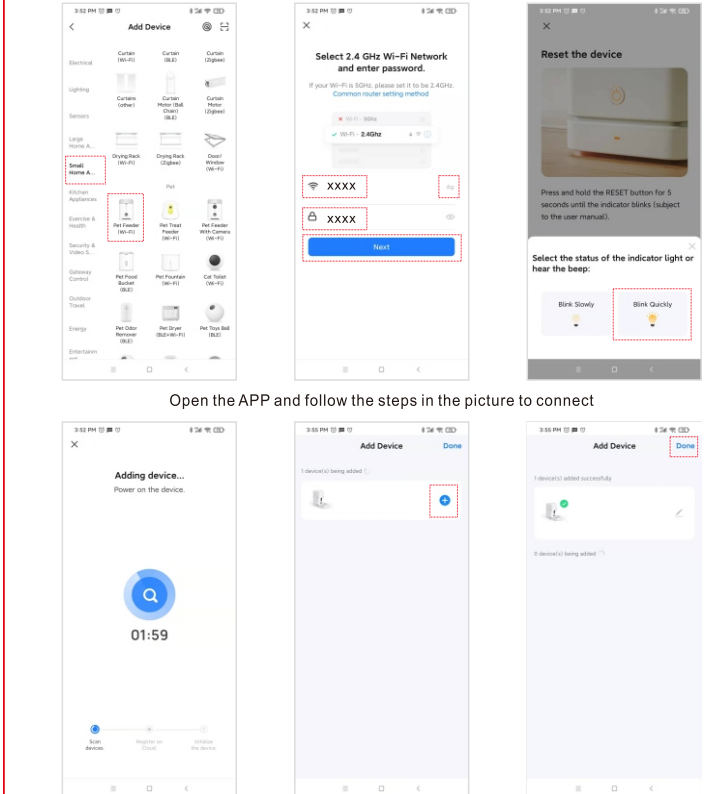

3.4. Video Version Pet Feeder Configuration

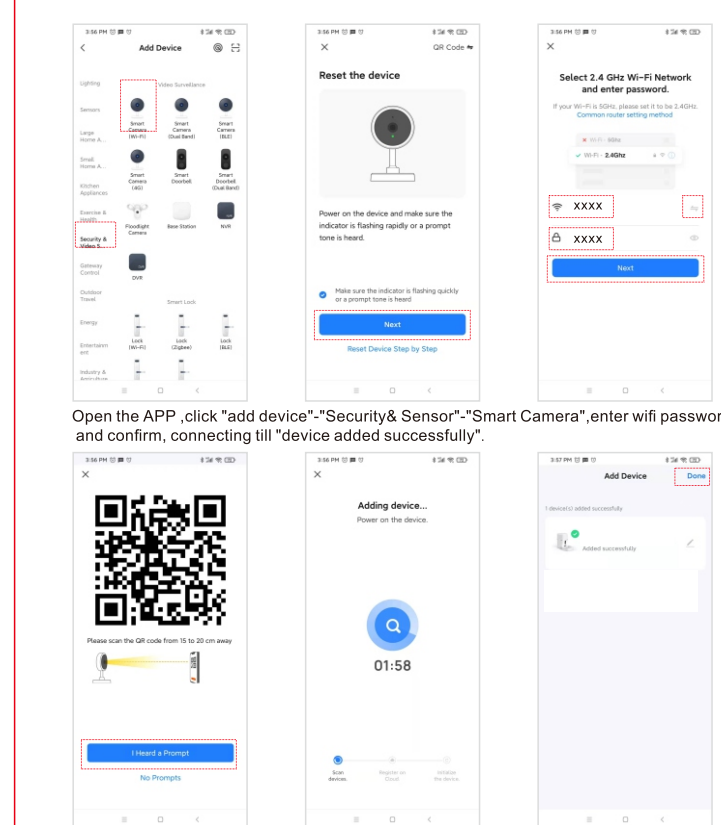

4. Video Feeder APP Interface Introduction

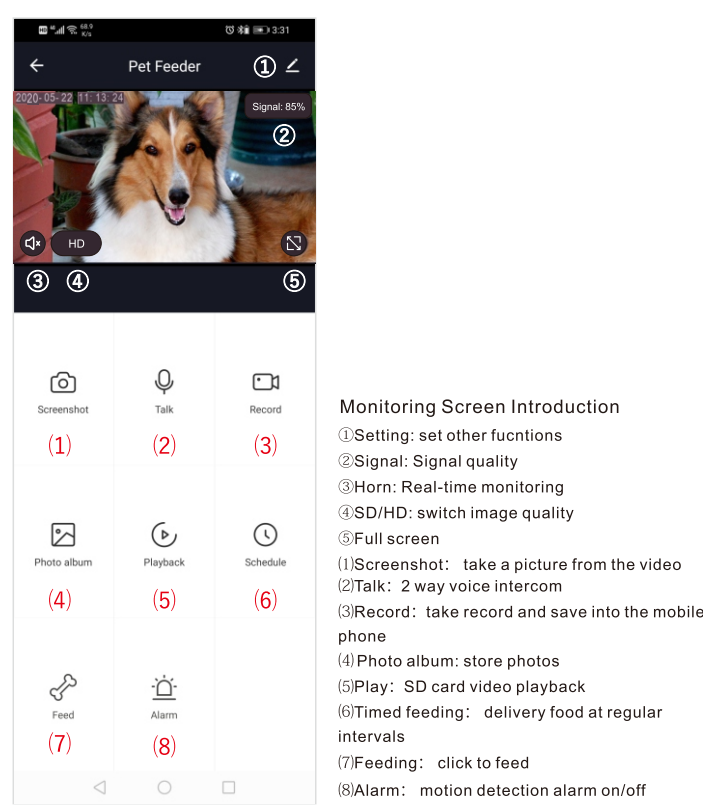

5. WiFi Feeder APP Interface Introduction

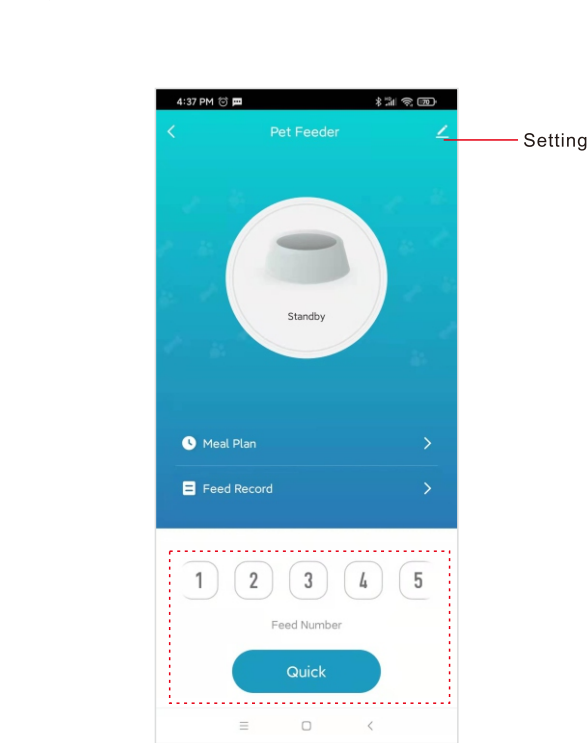

Cleaning/maintenance

After the feeder has been used for a period of time, the bowl and the bucket should be cleaned with a cleaning agent to avoid the occurrence of bacteria that affect the health of the pet due to the long time left by the food residue.

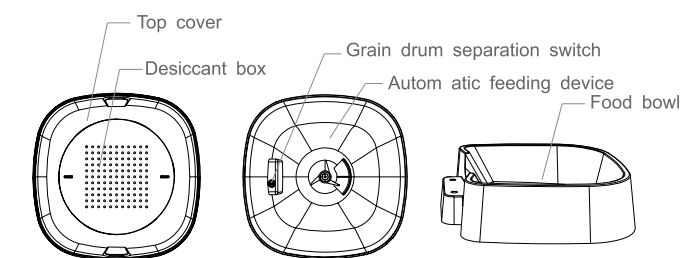

1. The upper showed machine parts can be removed from the main feeder and cleaned with detergent and water.
2. The drying box in the upper cover is rotated counterclockwise to remove it.
3. The grain drum is dismantled by rotating the "grain barrel separation switch".
4. The bowl is taken out by pulling down.
5. After cleaning, it must be dried or air-dried before being assembled into a whole main feeder for use.

▲ This feeder is suitable for dry foods smaller than 12 m m. Freeze-dried food is not available. Please keep the environment dry.

Attentions

1. Please place the device correctly; prevent the pet from tipping over the device. This device is only suitable for small and medium pets under 20kg.
2. Please replace the desiccant in the storage lid regularly. No desiccant is needed.
3. Please keep the food bucket dry and sealed, and check regularly to ensure food residue Precautions
4. Do not drop all substances other than pet dry food into the grain bin. Otherwise, the device may be used abnormally or even cause pet safety problems.
5. To prevent the pet from falling over the product, it is recommended to place the corner or against the wall.
6. The product anti-battering line should be installed as concealed as possible to prevent the equipment from being damaged by the pet biting the wire.
7. If children are using this device, be sure to use it under adult guidance.
8. After installing the spare dry battery, you can manually operate the device to provide normal power supply during power failure.
9. Regularly clean the food bucket and food bowl.
10. This device is not recommended for young pets within three months.

Maintenance records: _____
Maintenance time: _____
Fault conditions: _____
Fault cause: _____
Trouble shooting: _____
Return and exchange proof: _____
Date of validity: _____
Original device ID: _____
New device ID: _____
maintenance personnel signature: _____
Maintenance Department seal: _____

FAQ

- Q:The feeder is not connected, what is the problem, what to do?
- A:1. Check if the machine is normal. Check the status of the device indicator. After the power is turned on, the blue indicator light flashes. When the network is connected, it will be on. There will be a drop tone before the network is configured.
2. Check if the Wi-Fi username and password are normal. Wi-Fi username and password cannot have special characters. It is recommended to use English letters + number signs.
3. Uninstall the software and reinstall the software. Please authorize the APP to obtain the location information and access the network permissions during the installation process. Follow the above steps, and enter the correct wifi password. If you still have difficulties, please contact customer service.
- Q:When connecting the feeder, sometimes it can be connected normally, sometimes not, how to deal with it?
- A:Check if the machine's food outlet is blocked. At this time, the blue indicator is always on.
- Q:Why does the feeding time differ by tens of seconds from the current time?
- A:The parameters set on the APP will have an error of about 30 seconds depending on the timing of the network environment.
- Q:How to quickly reconnect after the machine is disconnected?
- A:1. Exit the APP and re-enter, wait for the data update.
2. Switches from the feeding interface to the video interface and waits for the video to refresh.
- Q:Feeder requirements for network type?
- A:The feeder must use a wifi signal that satisfies the wifi 802.11bgn protocol.